



DATA IMAGE CORPORATION

TFT Module Specification

ITEM NO.: FG050700DSSWDG10

Table of Contents

| | |
|---------------------------------------|----|
| 1. COVER & CONTENTS | 1 |
| 2. RECORD OF REVISION | 2 |
| 3. APPLICATION..... | 3 |
| 4. GENERAL SPECIFICATIONS | 3 |
| 5. ELECTRICAL CHARACTERISTICS | 3 |
| 6. BLOCK DIAGRAM | 4 |
| 7. PIN CONNECTIONS | 5 |
| 8. INTERFACE SPECIFICATIONS | 6 |
| 9. OPTICAL CHARACTERISTIC | 10 |
| 10. TOUCH PANEL CHARACTERISTICS | 12 |
| 11. QUALITY ASSURANCE | 13 |
| 12. LCM PRODUCT LABEL DEFINE | 14 |
| 13. PRECAUTIONS IN USE LCM | 16 |
| 14. OUTLINE DRAWING | 17 |
| 15. PACKAGE INFORMATION | 18 |

| | | | | |
|--------------------|-------------|--------------|-------------|--------------|
| Customer Companies | R&D Dept. | Q.C. Dept. | Eng. Dept. | Prod. Dept. |
| | <i>Jack</i> | <i>Eric</i> | <i>Paul</i> | <i>Heien</i> |
| Approved by | Version: | Issued Date: | Sheet Code: | Total Pages: |
| | B | 14/DEC/10' | | 18 |

2. RECORD OF REVISION

| Rev | Date | Item | Page | Comment |
|-----|------------|------------|---------|---------------------------------------------------------------------------------------------------------|
| 1 | 20/OCT/09' | | | Initial Preliminary |
| 2 | 13/OCT/09' | 5.3 8.3 | 3 9 | Add Drawing of LED array Modify: Color Data Input Assignment |
| A | 25/Mar/10' | 15,16 | 16,17 | Change OUTLINE DRAWING from rev:1 to rev:2 Release Rev A for production. Add: PACKAGE INFORMATION |
| B | 14/DEC/10' | 5.3 12 | 3 14 | 1.Modify LED dice Life Time from 25K hrs to 40K hrs 2.Revise LCM PRODUCT LABEL DEFINE |
| | | | | |

3. APPLICATION

Digital equipments which need color display, such as P.O.S, medical equipments and industrial equipments.

4. GENERAL SPECIFICATIONS

| Parameter | Specifications | Unit |
|-------------------------------------------------------------|------------------------------|------|
| Display resolution | (320X R.G.B) (W) x 240(H) | dot |
| Active area | 115.2(W) x 86.4(H) | mm |
| Screen size | 5.7(Diagonal) | inch |
| Dot pitch | 0.12(W) x 0.36(H) | mm |
| Color configuration | R.G.B. Stripe | |
| Overall dimension | 144 (W) x 104.6(H) x 14.8(D) | mm |
| Weight | 242 | g |
| Surface treatment | Anti-glare | |
| View Angle direction | 12 o'clock | |
| Our components and processes are compliant to RoHS standard | | |

5. ELECTRICAL CHARACTERISTICS

5.1 Absolute Maximum Ratings

GND=0V

| Parameter | Symbol | MIN. | MAX. | Unit | Remark |
|-----------------------|-----------------|------|----------------------|------|---------------------|
| Power supply voltage | V _{CC} | -0.3 | +7.0 | V | |
| Logic input voltage | V _I | -0.3 | V _{CC} +0.3 | V | |
| Operating temperature | Top | -20 | 70 | °C | Ambient temperature |
| Storage temperature | T _{st} | -30 | 80 | °C | Ambient temperature |

5.2 TFT-LCD Driving Conditions

GND=0V , Ta=25°C

| Parameter | Symbol | MIN. | Typ. | MAX. | Unit | Remark |
|---------------------------------|-----------------|--------------------|------|--------------------|------|-----------------------|
| Power Supply voltage | V _{CC} | +3.0 | +3.3 | +3.6 | V | |
| Power Supply Current | I _{CC} | | 130 | 150 | mA | V _{CC} =3.3V |
| "H" level logical input voltage | V _{IH} | 0.7V _{CC} | -- | 3.6 | V | |
| "L" level logical input voltage | V _{IL} | 0V | -- | 0.3V _{CC} | V | |

5.3 Backlight Driving Conditions

| Parameter | Symbol | Min. | Typ. | Max. | Unit | Remark |
|--------------------|----------------|------|-------|------|------|---------|
| LED current | I _L | -- | 140 | -- | mA | |
| VLED voltage | V _L | -- | 10.2 | 10.8 | V | |
| LED dice Life Time | | -- | 40000 | -- | hr | Note 1: |

Note 1: The "LED dice life time" is defined as the LED dice brightness decrease to 50% original brightness that the ambient temperature is 22 and LED dice current 20mA.

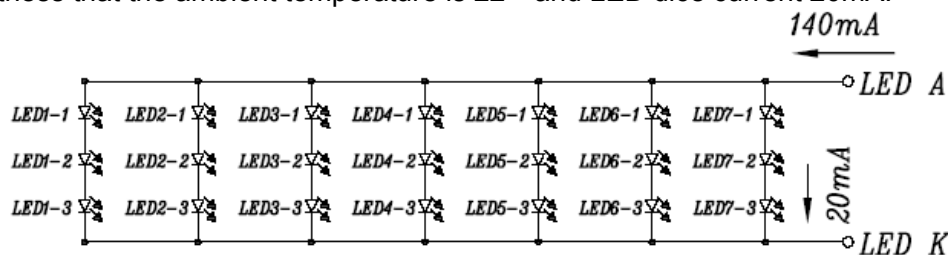

6. BLOCK DIAGRAM

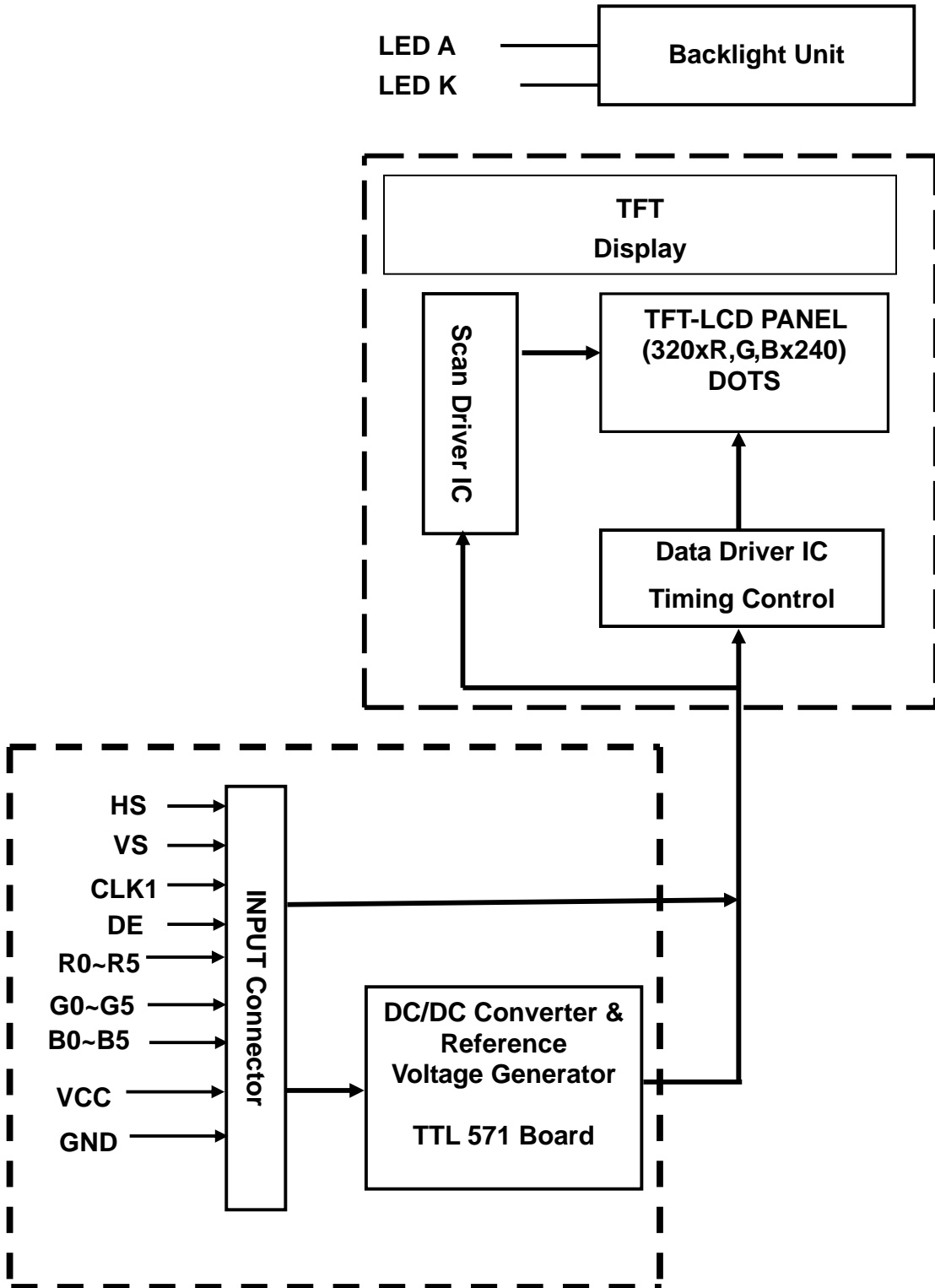

7. PIN CONNECTIONS

7.1 P1 Input Pins Connection (To TTL571 control board)

| Pin No | Symbol | Function | Remark |
|--------|------------|--------------------------------------------------------------------------|--------|
| 1 | GND | Ground for logic circuit | |
| 2 | CLK1 | Data sampling clock | |
| 3 | HS (HSYNC) | Horizontal synchronous signal | |
| 4 | VS (VSYNC) | Vertical synchronous signal | |
| 5 | GND | Ground for logic circuit | |
| 6 | R0 | Red pixel data(LSB) | |
| 7 | R1 | Red pixel data | |
| 8 | R2 | Red pixel data | |
| 9 | R3 | Red pixel data | |
| 10 | R4 | Red pixel data | |
| 11 | R5 | Red pixel data(MSB) | |
| 12 | GND | Ground for logic circuit | |
| 13 | G0 | Green pixel data(LSB) | |
| 14 | G1 | Green pixel data | |
| 15 | G2 | Green pixel data | |
| 16 | G3 | Green pixel data | |
| 17 | G4 | Green pixel data | |
| 18 | G5 | Green pixel data(MSB) | |
| 19 | GND | Ground for logic circuit | |
| 20 | B0 | Blue pixel data(LSB) | |
| 21 | B1 | Blue pixel data | |
| 22 | B2 | Blue pixel data | |
| 23 | B3 | Blue pixel data | |
| 24 | B4 | Blue pixel data | |
| 25 | B5 | Blue pixel data(MSB) | |
| 26 | GND | Ground for logic circuit | |
| 27 | DE | Data Enable (connected to GND, if sync mode) | |
| 28 | Vcc | Power Supply : +3.3V | |
| 29 | Vcc | Power Supply : +3.3V | |
| 30 | R/L | Horizontal display mode select signal Left / Right Scan control input | *2 |
| 31 | U/D | Vertical display mode select signal Up / Down Scan control input | *2 |
| 32 | NC | No Connection | |
| 33 | GND | Ground for logic circuit | |

*1 The horizontal display start timing is settled in accordance with a rising timing of DE signal.
Don't keep DE "High" during operation.

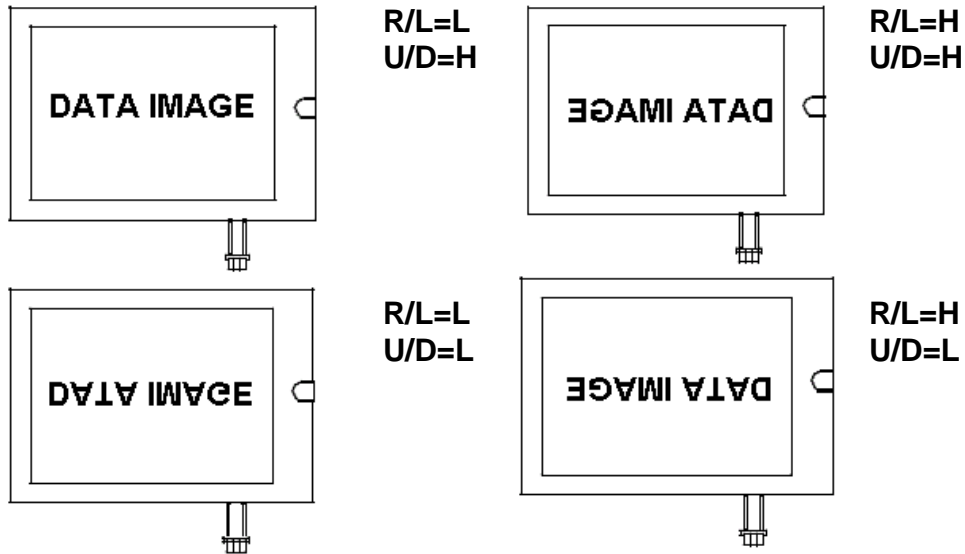

8. INTERFACE SPECIFICATIONS

8.1 Input Signal Timing Specifications

| Parameter | | Symbol | MIN. | TYP. | MAX. | Unit | Remarks |
|--------------------------|-------------------|--------|------|------|------|-------|---------|
| CLK | Frequency | 1/Tc | | 7.21 | | MHz | |
| | Duty ratio | Th/Tc | 40 | 50 | 60 | % | |
| DATA | Setup time | Tds | 12 | | | ns | |
| | Hold time | Tdh | 12 | | | ns | |
| Horizontal synchronizing | Period | TH | -- | 453 | -- | Clock | |
| | Pulse width | THp | -- | 31 | -- | Clock | |
| | Horizontal period | THd | -- | 320 | -- | Clock | |
| | Blank porch | THb | -- | 69 | -- | Clock | |
| | Front porch | THf | -- | 33 | -- | Clock | |
| Vertical synchronizing | Period | TV | -- | 267 | -- | Line | |
| | Pulse width | TVp | -- | 6 | -- | Line | |
| | Vertical period | TVd | -- | 240 | -- | Line | |
| | Blank porch | TVb | -- | 18 | -- | Line | |
| | Front porch | TVf | -- | 3 | -- | Line | |

Note:

- ◇ In case of using the slow frequency, the deterioration of display flicker etc may occur.
- ◇ The timing characteristics are basically fixed as above.

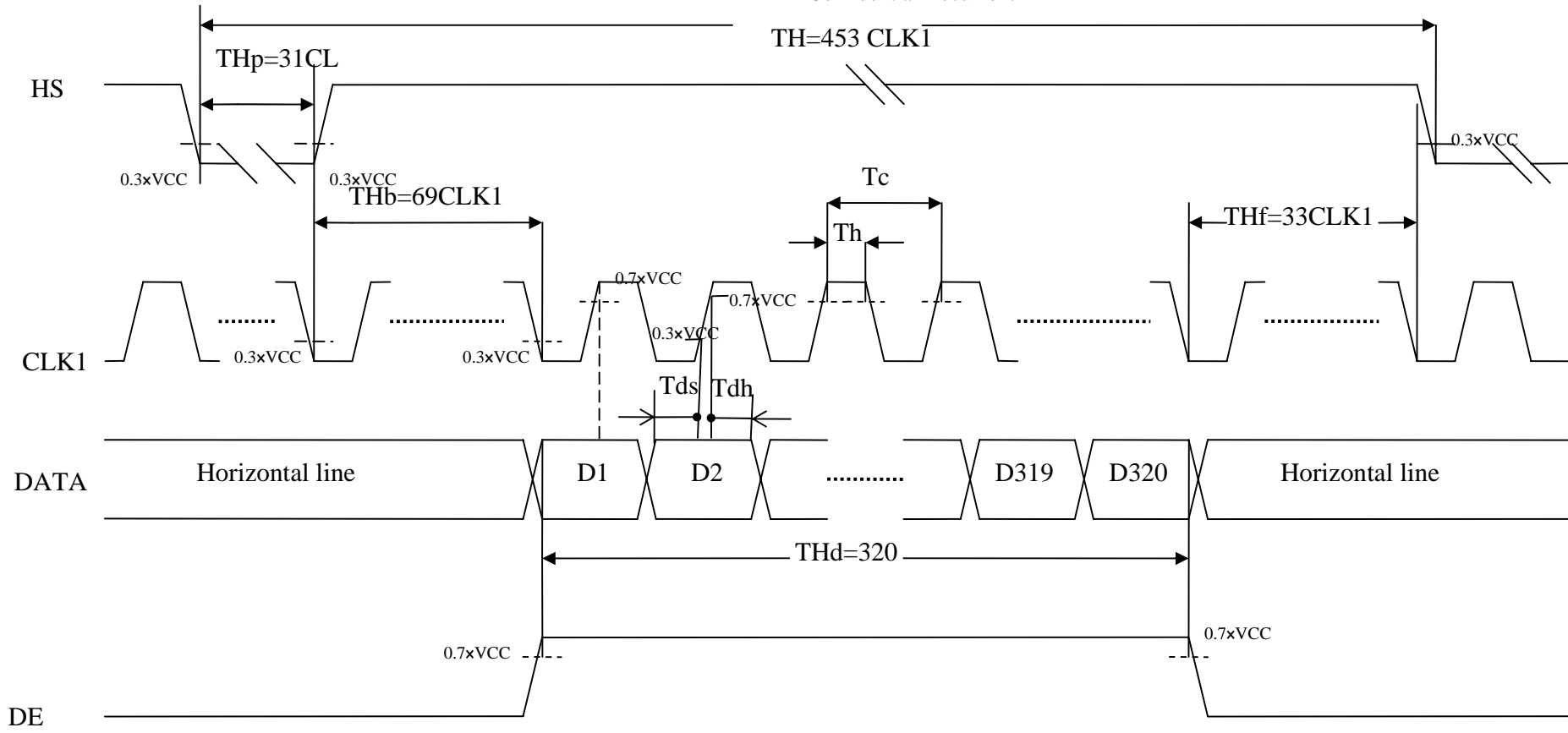

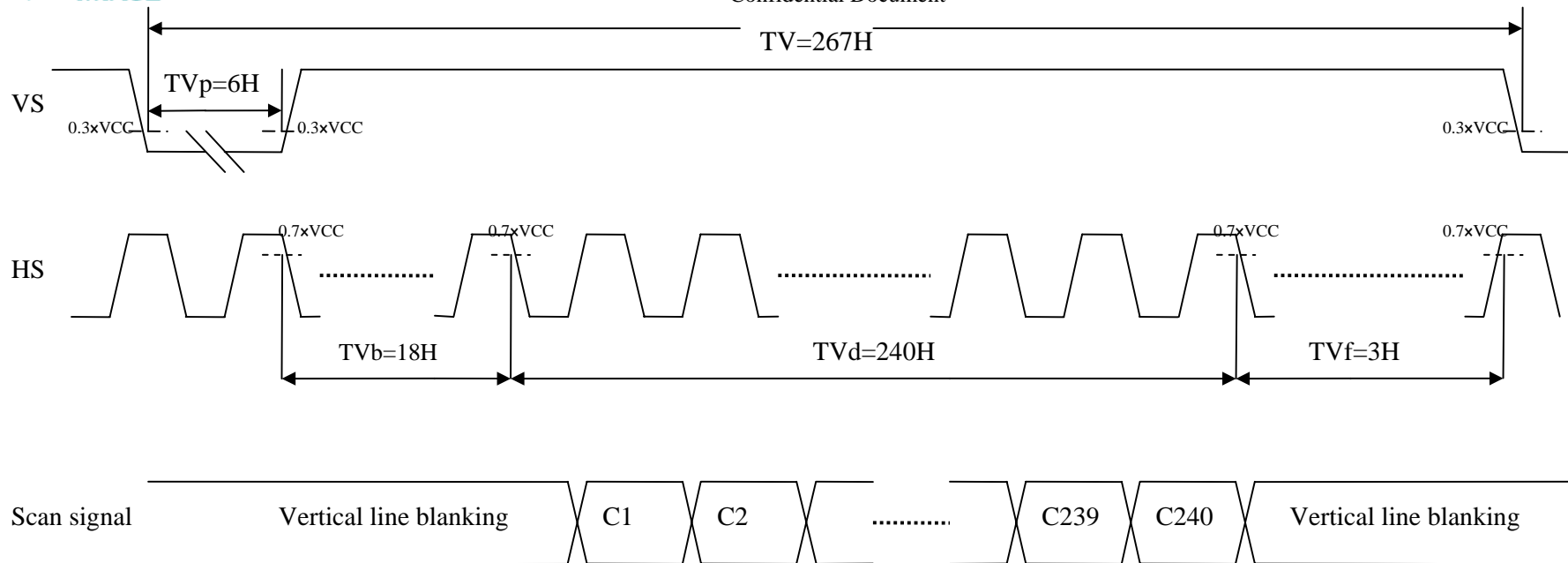

8.2 Power Off/On Sequence Timing

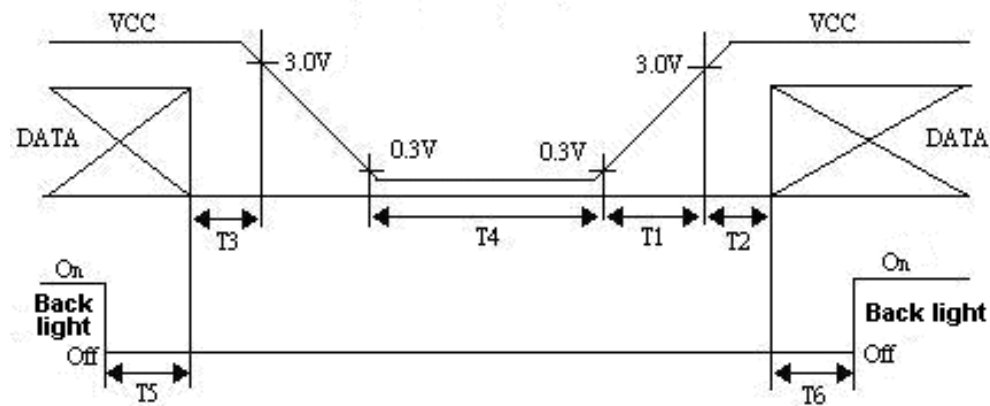

Timing Specifications:

$0 < T1 \leq 15\text{mS}$

$T2 > 0.5\text{S}$

$0 < T3 \leq 0.1\text{S}$

$T4 > 1\text{S}$

$T5 > 0.1\text{S}$

$T6 > 0.1\text{S}$

8.3 Color Data Input Assignment

| | | Data Signal | | | | | | | | | | | | | | | | | |
|---------------------|----------------|-------------|----|----|----|----|-------|----|----|----|----|------|----|----|----|----|----|----|----|
| | | Red | | | | | Green | | | | | Blue | | | | | | | |
| Color | | R5 | R4 | R3 | R2 | R1 | R0 | G5 | G4 | G3 | G2 | G1 | G0 | B5 | B4 | B3 | B2 | B1 | B0 |
| Basic Colors | Black | 0 | 0 | 0 | 0 | 0 | 0 | 0 | 0 | 0 | 0 | 0 | 0 | 0 | 0 | 0 | 0 | 0 | 0 |
| | Red | 1 | 1 | 1 | 1 | 1 | 1 | 0 | 0 | 0 | 0 | 0 | 0 | 0 | 0 | 0 | 0 | 0 | 0 |
| | Green | 0 | 0 | 0 | 0 | 0 | 0 | 1 | 1 | 1 | 1 | 1 | 1 | 0 | 0 | 0 | 0 | 0 | 0 |
| | Blue | 0 | 0 | 0 | 0 | 0 | 0 | 0 | 0 | 0 | 0 | 0 | 0 | 1 | 1 | 1 | 1 | 1 | 1 |
| | Cyan | 0 | 0 | 0 | 0 | 0 | 0 | 1 | 1 | 1 | 1 | 1 | 1 | 1 | 1 | 1 | 1 | 1 | 1 |
| | Magenta | 1 | 1 | 1 | 1 | 1 | 1 | 0 | 0 | 0 | 0 | 0 | 0 | 1 | 1 | 1 | 1 | 1 | 1 |
| | Yellow | 1 | 1 | 1 | 1 | 1 | 1 | 1 | 1 | 1 | 1 | 1 | 1 | 0 | 0 | 0 | 0 | 0 | 0 |
| | White | 1 | 1 | 1 | 1 | 1 | 1 | 1 | 1 | 1 | 1 | 1 | 1 | 1 | 1 | 1 | 1 | 1 | 1 |
| Gray Scale of Red | Red(0) / Dark | 0 | 0 | 0 | 0 | 0 | 0 | 0 | 0 | 0 | 0 | 0 | 0 | 0 | 0 | 0 | 0 | 0 | 0 |
| | Red(1) | 0 | 0 | 0 | 0 | 0 | 1 | 0 | 0 | 0 | 0 | 0 | 0 | 0 | 0 | 0 | 0 | 0 | 0 |
| | Red(2) | 0 | 0 | 0 | 0 | 1 | 0 | 0 | 0 | 0 | 0 | 0 | 0 | 0 | 0 | 0 | 0 | 0 | 0 |
| | : | : | : | : | : | : | : | : | : | : | : | : | : | : | : | : | : | : | : |
| | : | : | : | : | : | : | : | : | : | : | : | : | : | : | : | : | : | : | : |
| | Red(61) | 1 | 1 | 1 | 1 | 0 | 1 | 0 | 0 | 0 | 0 | 0 | 0 | 0 | 0 | 0 | 0 | 0 | 0 |
| | Red(62) | 1 | 1 | 1 | 1 | 1 | 0 | 0 | 0 | 0 | 0 | 0 | 0 | 0 | 0 | 0 | 0 | 0 | 0 |
| | Red(63) | 1 | 1 | 1 | 1 | 1 | 1 | 0 | 0 | 0 | 0 | 0 | 0 | 0 | 0 | 0 | 0 | 0 | 0 |
| Gray Scale of Green | Green(0)/ Dark | 0 | 0 | 0 | 0 | 0 | 0 | 0 | 0 | 0 | 0 | 0 | 0 | 0 | 0 | 0 | 0 | 0 | 0 |
| | Green(1) | 0 | 0 | 0 | 0 | 0 | 0 | 0 | 0 | 0 | 0 | 0 | 1 | 0 | 0 | 0 | 0 | 0 | 0 |
| | Green(2) | 0 | 0 | 0 | 0 | 0 | 0 | 0 | 0 | 0 | 0 | 1 | 0 | 0 | 0 | 0 | 0 | 0 | 0 |
| | : | : | : | : | : | : | : | : | : | : | : | : | : | : | : | : | : | : | : |
| | : | : | : | : | : | : | : | : | : | : | : | : | : | : | : | : | : | : | : |
| | Green(61) | 0 | 0 | 0 | 0 | 0 | 0 | 1 | 1 | 1 | 1 | 0 | 1 | 0 | 0 | 0 | 0 | 0 | 0 |
| | Green(62) | 0 | 0 | 0 | 0 | 0 | 0 | 1 | 1 | 1 | 1 | 1 | 0 | 0 | 0 | 0 | 0 | 0 | 0 |
| | Green(63) | 0 | 0 | 0 | 0 | 0 | 0 | 1 | 1 | 1 | 1 | 1 | 1 | 0 | 0 | 0 | 0 | 0 | 0 |
| Gray Scale of Blue | Blue(0)/ Dark | 0 | 0 | 0 | 0 | 0 | 0 | 0 | 0 | 0 | 0 | 0 | 0 | 0 | 0 | 0 | 0 | 0 | 0 |
| | Blue (1) | 0 | 0 | 0 | 0 | 0 | 0 | 0 | 0 | 0 | 0 | 0 | 0 | 0 | 0 | 0 | 0 | 0 | 1 |
| | Blue (2) | 0 | 0 | 0 | 0 | 0 | 0 | 0 | 0 | 0 | 0 | 0 | 0 | 0 | 0 | 0 | 0 | 1 | 0 |
| | : | : | : | : | : | : | : | : | : | : | : | : | : | : | : | : | : | : | : |
| | : | : | : | : | : | : | : | : | : | : | : | : | : | : | : | : | : | : | : |
| | Blue (61) | 0 | 0 | 0 | 0 | 0 | 0 | 0 | 0 | 0 | 0 | 0 | 0 | 1 | 1 | 1 | 1 | 0 | 1 |
| | Blue (62) | 0 | 0 | 0 | 0 | 0 | 0 | 0 | 0 | 0 | 0 | 0 | 0 | 1 | 1 | 1 | 1 | 1 | 0 |
| | Blue (63) | 0 | 0 | 0 | 0 | 0 | 0 | 0 | 0 | 0 | 0 | 0 | 0 | 1 | 1 | 1 | 1 | 1 | 1 |

Correspondence between Data and Display Position

| | S960 | S959 | S958 | S957 | S956 | S955 | S954 | S953 | ----- | S002 | S001 |
|------|------|------|------|------|------|------|------|------|-------|------|------|
| C001 | B320 | G320 | R320 | B319 | G319 | R319 | B318 | G318 | | G001 | R001 |
| ⋮ | | | | | | | | | | | |
| C240 | B320 | G320 | R320 | B319 | G319 | R319 | B318 | G318 | | G001 | R001 |

9. OPTICAL CHARACTERISTIC

9-1. Specification:

| Item | Symbol | Condition | Min. | Typ. | Max. | Unit | Remark | |
|--------------------|--------|----------------------------|-------------|------|------|-------------------|--------|--------|
| Response time | Rise | $\theta=0^\circ$ | - | 15 | 30 | ms | Note 4 | |
| | Fall | | - | 35 | 50 | ms | | |
| Contrast ratio | CR | At optimized viewing angle | 300 | 350 | | | Note 5 | |
| Viewing angle | Top | θ_{y+} | CR \geq 5 | 60 | 70 | - | Deg. | Note 6 |
| | Bottom | θ_{y-} | | 40 | 50 | - | | |
| | Left | θ_{x-} | | 60 | 70 | - | | |
| | Right | θ_{x+} | | 60 | 70 | - | | |
| Brightness | | $\theta=0^\circ$ | 250 | 320 | -- | cd/m ² | Note 7 | |
| Uniformity | | | 75 | -- | | % | Note 9 | |
| White chromaticity | X | $\theta=0^\circ$ | 0.25 | 0.30 | 0.35 | | Note 7 | |
| | y | | 0.30 | 0.35 | 0.40 | | | |

Note 1: Ambient temperature =25°C. LED current = 140 mA..

Note 2: To be measured in the dark room.

Note 3: To be measured on the center area of panel with a viewing cone of 1° by Topcon luminance meter BM-7A, after 10 minutes operation.

Note 4: Definition of response time:

The output signals of photo-detector are measured when the input signals are changed from “white” to “black”(rising time) and from “black” to “white”(falling time),respectively. The response time is defined as the time interval between the 10% and 90% of amplitudes.

Refer to figure as shown below.

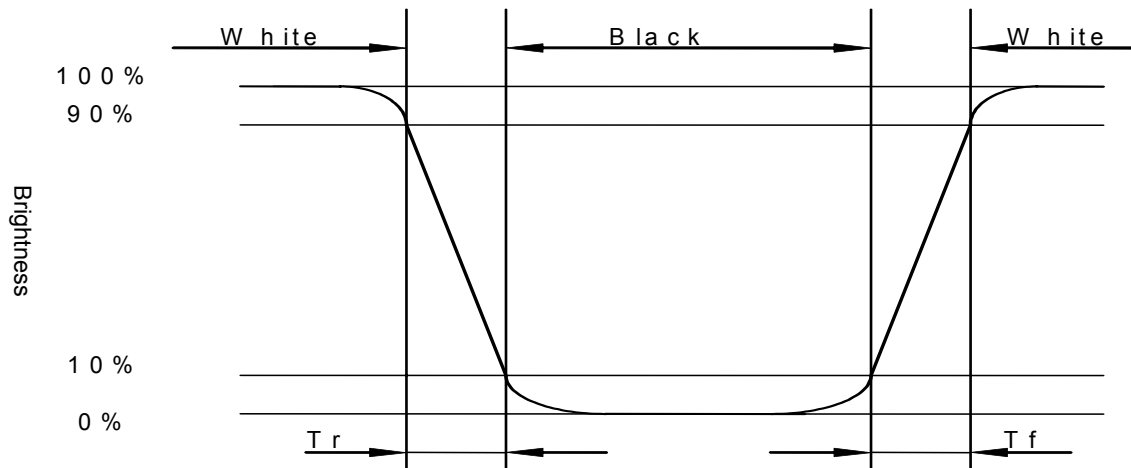

Note5: Definition of contrast ratio:

Contrast ratio is calculated with the following formula.

$$\text{Contrast ratio (CR)} = \frac{\text{Photo-detector output when LCD is at "White" state}}{\text{Photo-detector output when LCD is at "Black" state}}$$

Note 6: Definition of viewing angle:
Refer to figure as below.

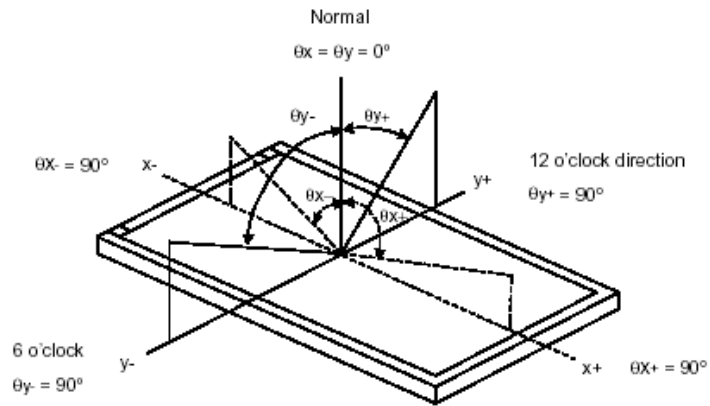

Note 7: Measured at the center area of the panel when all the input terminals of LCD panel are electrically opened.

Note 8: The method of optical measurement:

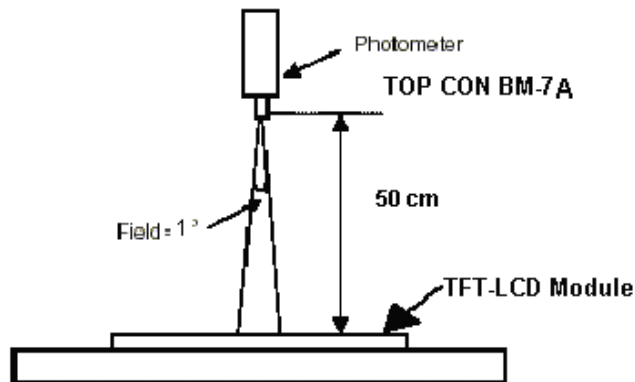

Note 9: Definition of Brightness Uniformity (Buni):

Luminance Measuring Points

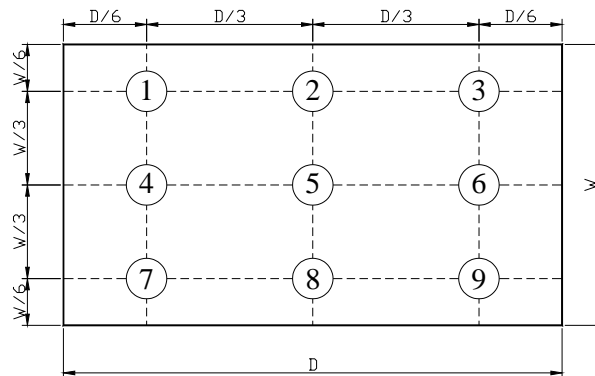

$$B\text{-uni} = \frac{\text{Minimum luminance of 9 points}}{\text{Maximum luminance of 9 points}}$$

10. TOUCH PANEL CHARACTERISTICS

1. Input Method and Activation Force

| Input Method | Average Activation Force |
|-----------------------------|--------------------------|
| 0.8mm dia. Delrin stylus | 5gf~100gf |
| 8.0mm dia. Silicon "finger" | 5gf~100gf |

2. Typical Optical Characteristics

| ITEM | Parameter |
|----------------------------|-----------|
| Visible Light Transmission | ≥80% |
| Haze | <10% |

3. Electrical Specification

| ITEM | Parameter |
|--------------------------|--------------------------------|
| Operating Voltage | DC 5V |
| Contact current | According to individual design |
| Circuit close resistance | X 220Ω~690Ω |
| | Y 300Ω~820Ω |
| Circuit open resistance | ≥20MΩ at 25V DC |
| Contact bounce | ≤10ms |
| Linear Test | ≤1.5% |
| Capacitance | <100nF |

4. Linearity

| ITEM | Parameter |
|-------------------------------------|-----------|
| Linear Test Specification Direction | X ≤1.5% |
| | Y ≤1.5% |

5. Specification

| ITEM | Parameter |
|-----------------------|-------------|
| Operating Temperature | -20°C~+70°C |
| Storage Temperature | -30°C~+80°C |

6. Durability test:

6.1 Touch panel is hit 1 millions times with a silicone rubber of R8 finger, hitting rate is by 250g at 2 times per second. The measurement must satisfy the following:

- Circuit close resistance: x 220Ω~690Ω ;
y 300Ω~820Ω
- Circuit open resistance: ≥20MΩ at 25V DC
- Contact bounce: ≤10ms
- Linearity test: ≤1.5%

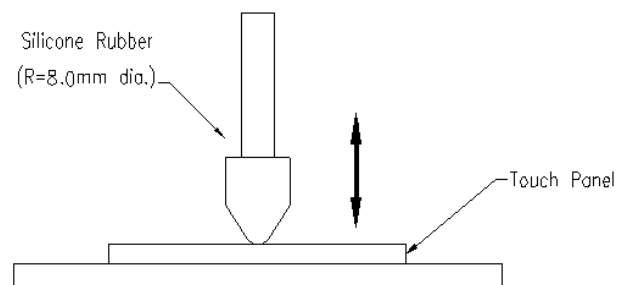

6.2 Stylus writing

Touch panel is drawn by R0.8 Delrin stylus pen, at 250g forces, repeat one inch by 100k times. The measurement must satisfy the following:

- Circuit close resistance: x 220Ω~690Ω ;
y 300Ω~820Ω
- Circuit open resistance: ≥20MΩ at 25V DC
- Contact bounce: ≤10ms
- Linearity test: ≤1.5%

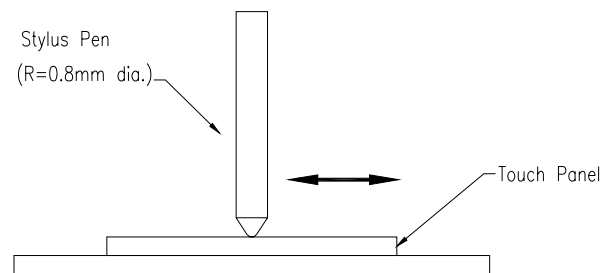

11. QUALITY ASSURANCE

11.1 Test Condition

11.1.1 Temperature and Humidity(Ambient Temperature)

Temperature : $25 \pm 5^{\circ}\text{C}$

Humidity : $65 \pm 5\%$

11.1.2 Operation

Unless specified otherwise, test will be conducted under function state.

11.1.3 Container

Unless specified otherwise, vibration test will be conducted to the product itself without putting it in a container.

11.1.4 Test Frequency

In case of related to deterioration such as shock test. It will be conducted only once.

11.1.5 Test Method

| No. | Reliability Test Item & Level | Test Level |
|-----|---------------------------------------------------|--------------------------------------------------------------------------------------------------------------|
| 1 | High Temperature Storage Test | T=80°C,240hrs |
| 2 | Low Temperature Storage Test | T=-30°C,240hrs |
| 3 | High Temperature Operation Test | T=70°C,240hrs |
| 4 | Low Temperature Operation Test | T=-20°C,240hrs |
| 5 | High Temperature and High Humidity Operation Test | T=60°C,90% RH,240hrs |
| 6 | Thermal Cycling Test (No operation) | -30°C → +25°C → +80°C,200 Cycles 30 min 5min 30 min |
| 7 | Vibration Test (No operation) | Frequency:0 ~ 55 Hz Amplitude:1.5 mm Sweep Time:11min Test Period:6 Cycles for each Direction of X,Y,Z |
| 8 | Electrostatic Discharge Test (No operation) | 150pF,330Ω Air:± 15KV;Contact: ± 8KV 10 times/point;4 points/panel face |

12. LCM PRODUCT LABEL DEFINE

Product Label style:

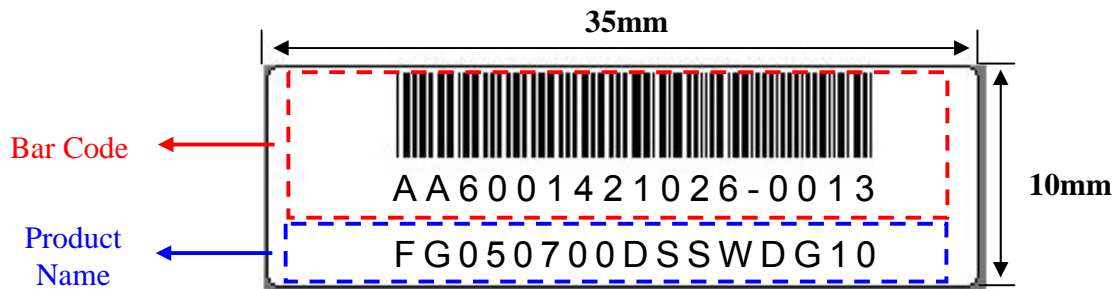

BarCode Define:

A A 6 0014 2 10 26-0013

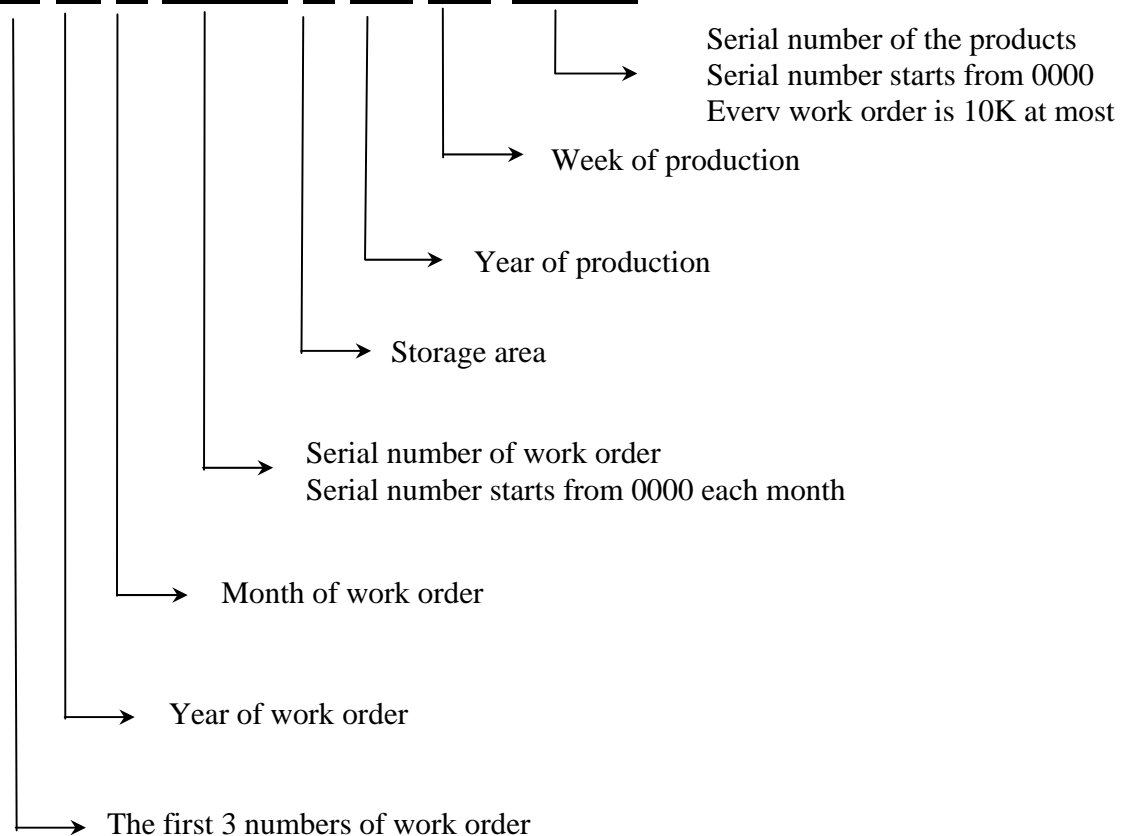

Product Name Define:

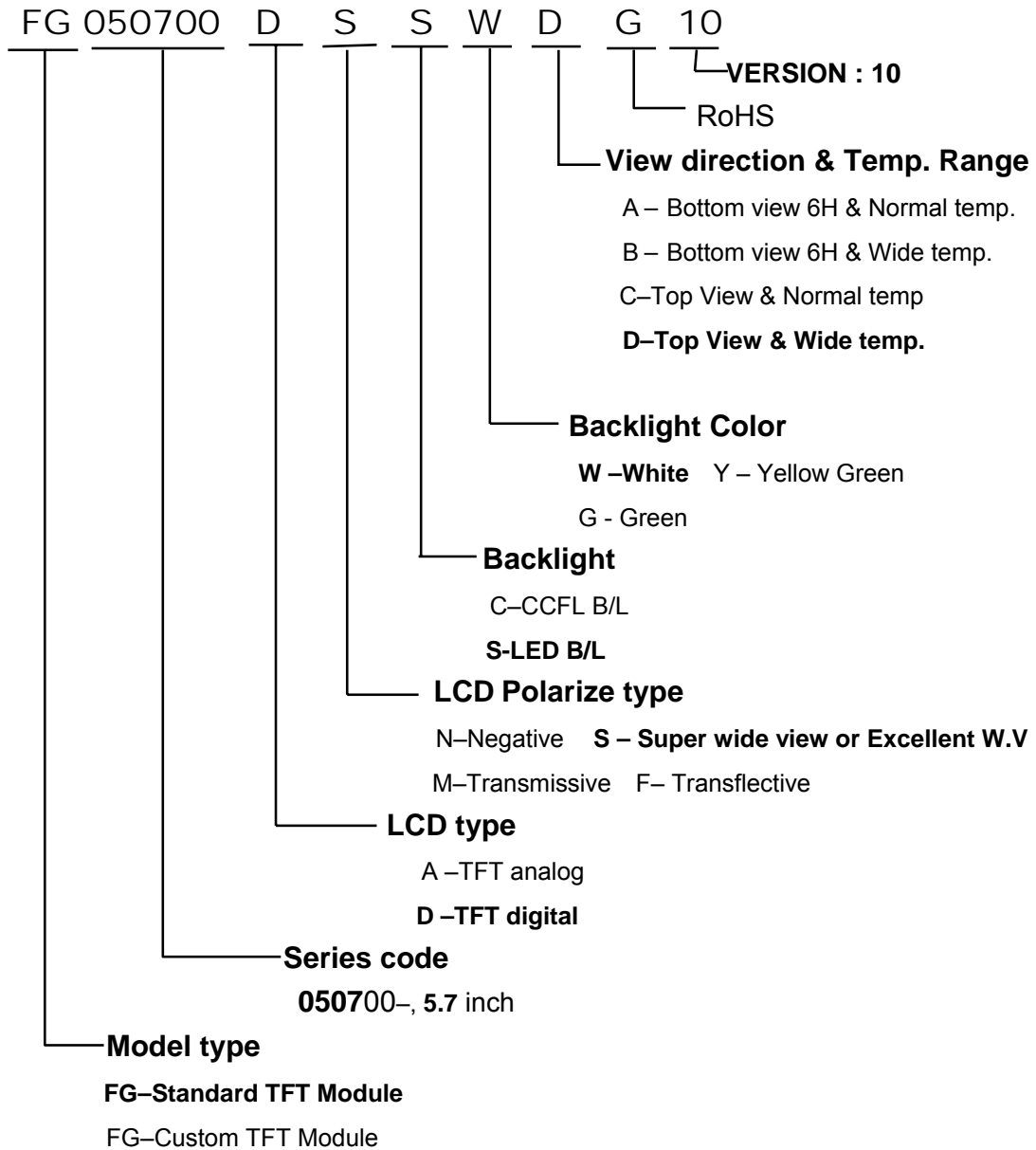

13. PRECAUTIONS IN USE LCM

1. LIQUID CRYSTAL DISPLAY (LCD)

LCD is made up of glass, organic sealant, organic fluid, and polymer based polarizers. The following precautions should be taken when handling,

- (1). Keep the temperature within range of use and storage. Excessive temperature and humidity could cause polarization degradation, polarizer peel off or bubble.
- (2). Do not contact the exposed polarizers with anything harder than an HB pencil lead. To clean dust off the display surface, wipe gently with cotton, chamois or other soft material soaked in petroleum benzin.
- (3). Wipe off saliva or water drops immediately. Contact with water over a long period of time may cause polarizer deformation or color fading, while an active LCD with water condensation on its surface will cause corrosion of ITO electrodes.
- (4). Glass can be easily chipped or cracked from rough handling, especially at corners and edges.
- (5). Do not drive LCD with DC voltage.

2. Liquid Crystal Display Modules

2.1 Mechanical Considerations

LCM are assembled and adjusted with a high degree of precision. Avoid excessive shocks and do not make any alterations or modifications. The following should be noted.

- (1). Do not tamper in any way with the tabs on the metal frame.
- (2). Do not modify the PCB by drilling extra holes, changing its outline, moving its components or modifying its pattern.
- (3). Do not touch the elastomer connector, especially insert an backlight panel (for example, EL).
- (4). When mounting a LCM make sure that the PCB is not under any stress such as bending or twisting. Elastomer contacts are very delicate and missing pixels could result from slight dislocation of any of the elements.
- (5). Avoid pressing on the metal bezel, otherwise the elastomer connector could be deformed and lose contact, resulting in missing pixels.

2.2. Static Electricity

LCM contains CMOS LSI's and the same precaution for such devices should apply, namely

- (1). The operator should be grounded whenever he/she comes into contact with the module. Never touch any of the conductive parts such as the LSI pads, the copper leads on the PCB and the interface terminals with any parts of the human body.
- (2). The modules should be kept in antistatic bags or other containers resistant to static for storage.
- (3). Only properly grounded soldering irons should be used.
- (4). If an electric screwdriver is used, it should be well grounded and shielded from commutator sparks.

- (5) The normal static prevention measures should be observed for work clothes and working benches; for the latter conductive (rubber) mat is recommended.
- (6). Since dry air is inductive to statics, a relative humidity of 50-60% is recommended.

2.3 Soldering

- (1). Solder only to the I/O terminals.
- (2). Use only soldering irons with proper grounding and no leakage.
- (3). Soldering temperature : $280^{\circ}\text{C} \pm 10^{\circ}\text{C}$
- (4). Soldering time: 3 to 4 sec.
- (5). Use eutectic solder with resin flux fill.
- (6). If flux is used, the LCD surface should be covered to avoid flux spatters. Flux residue should be removed after wards.

2.4 Operation

- (1). The viewing angle can be adjusted by varying the LCD driving voltage V0.
- (2). Driving voltage should be kept within specified range; excess voltage shortens display life.
- (3). Response time increases with decrease in temperature.
- (4). Display may turn black or dark blue at temperatures above its operational range; this is (however not pressing on the viewing area) may cause the segments to appear "fractured".
- (5). Mechanical disturbance during operation (such as pressing on the viewing area) may cause the segments to appear "fractured".

2.5 Storage

If any fluid leaks out of a damaged glass cell, wash off any human part that comes into contact with soap and water. Never swallow the fluid. The toxicity is extremely low but caution should be exercised at all the time.

2.6 Limited Warranty

Unless otherwise agreed between DATA IMAGE and customer, DATA IMAGE will replace or repair any of its LCD and LCM which is found to be defective electrically and visually when inspected in accordance with DATA IMAGE acceptance standards, for a period on one year from date of shipment. Confirmation of such date shall be based on freight documents. The warranty liability of DATA IMAGE is limited to repair and/or replacement on the terms set forth above. DATA IMAGE will not responsible for any subsequent or consequential events.

Confidential Document
14. OUTLINE DRAWING

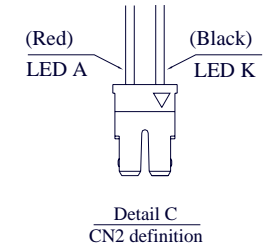
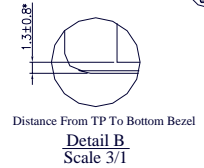
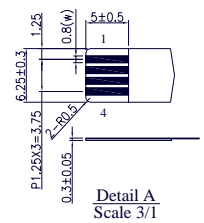
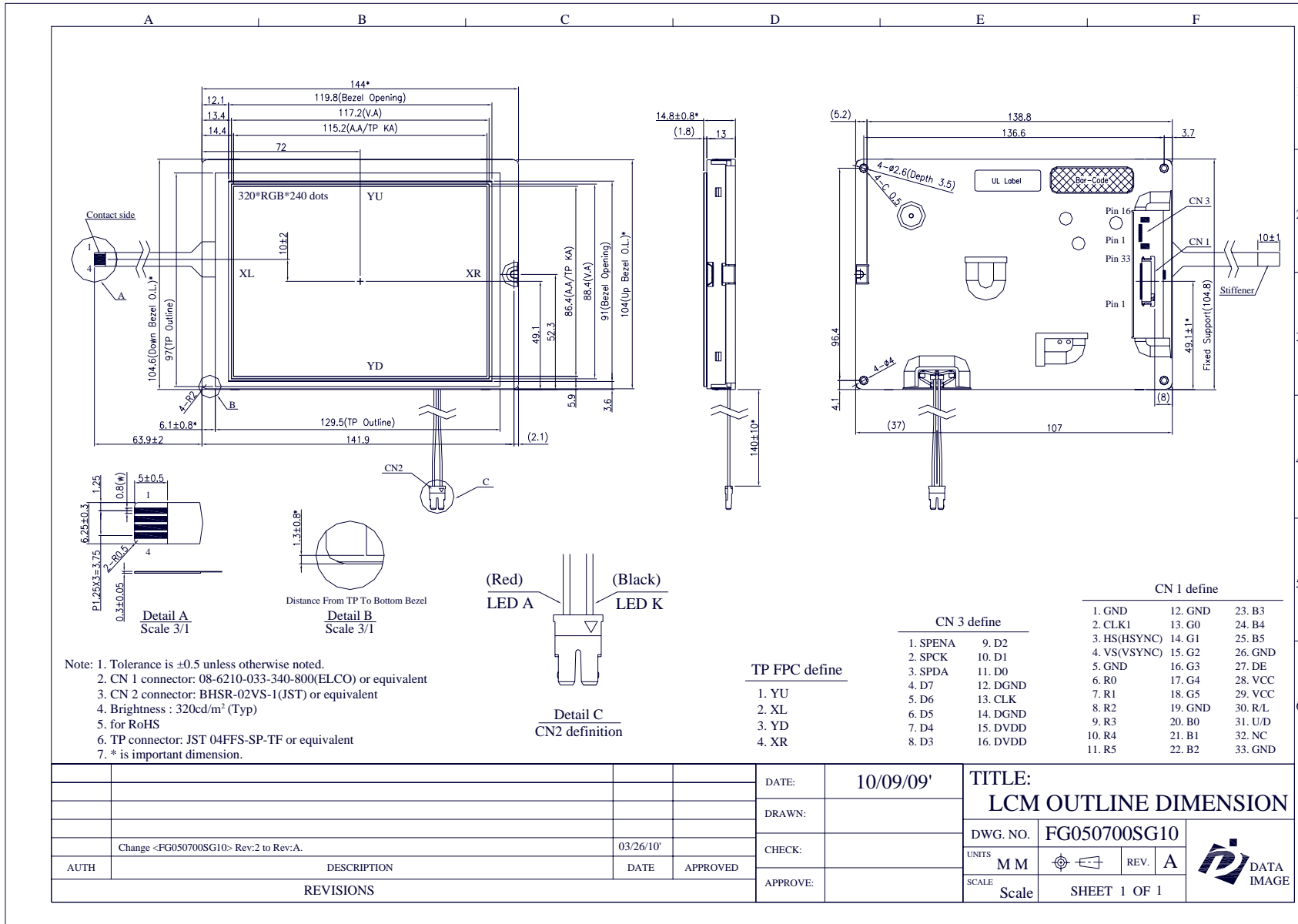

- Note: 1. Tolerance is ±0.5 unless otherwise noted.
 2. CN 1 connector: 08-6210-033-340-800(ELCO) or equivalent
 3. CN 2 connector: BHSR-02VS-1(JST) or equivalent
 4. Brightness : 320cd/m² (Typ)
 5. for RoHS
 6. TP connector: JST 04FFS-SP-TF or equivalent
 7. * is important dimension.

- TP FPC define**
- 1. YU
 - 2. XL
 - 3. YD
 - 4. XR

- CN 3 define**
- 1. SPENA
 - 2. SPCK
 - 3. SPDA
 - 4. D7
 - 5. D6
 - 6. D5
 - 7. D4
 - 8. D3
 - 9. D2
 - 10. D1
 - 11. D0
 - 12. DGND
 - 13. CLK
 - 14. DGND
 - 15. DVDD
 - 16. DVDD

- CN 1 define**
- 1. GND
 - 2. CLK1
 - 3. HS(HSYNC)
 - 4. VS(VSYNC)
 - 5. GND
 - 6. R0
 - 7. R1
 - 8. R2
 - 9. R3
 - 10. R4
 - 11. R5
 - 12. GND
 - 13. G0
 - 14. G1
 - 15. G2
 - 16. G3
 - 17. G4
 - 18. G5
 - 19. GND
 - 20. B0
 - 21. B1
 - 22. B2
 - 23. B3
 - 24. B4
 - 25. B5
 - 26. GND
 - 27. DE
 - 28. VCC
 - 29. VCC
 - 30. R/L
 - 31. U/D
 - 32. NC
 - 33. GND

| | | | | | | | | | |
|-----------|---------------------------------------|-----------|----------|----------|-----------|----------|-------|-----------------------|---|
| | | | | DATE: | 10/09/09' | TITLE: | | LCM OUTLINE DIMENSION | |
| | | | | DRAWN: | | DWG. NO. | | FG050700SG10 | |
| | | | | CHECK: | | UNITS | M M | REV. | A |
| | | | | APPROVE: | | SCALE | Scale | SHEET 1 OF 1 | |
| REVISIONS | | | | | | | | | |
| AUTH | DESCRIPTION | DATE | APPROVED | | | | | | |
| | Change <FG050700SG10> Rev:2 to Rev:A. | 03/26/10' | | | | | | | |

15. PACKAGE INFORMATION

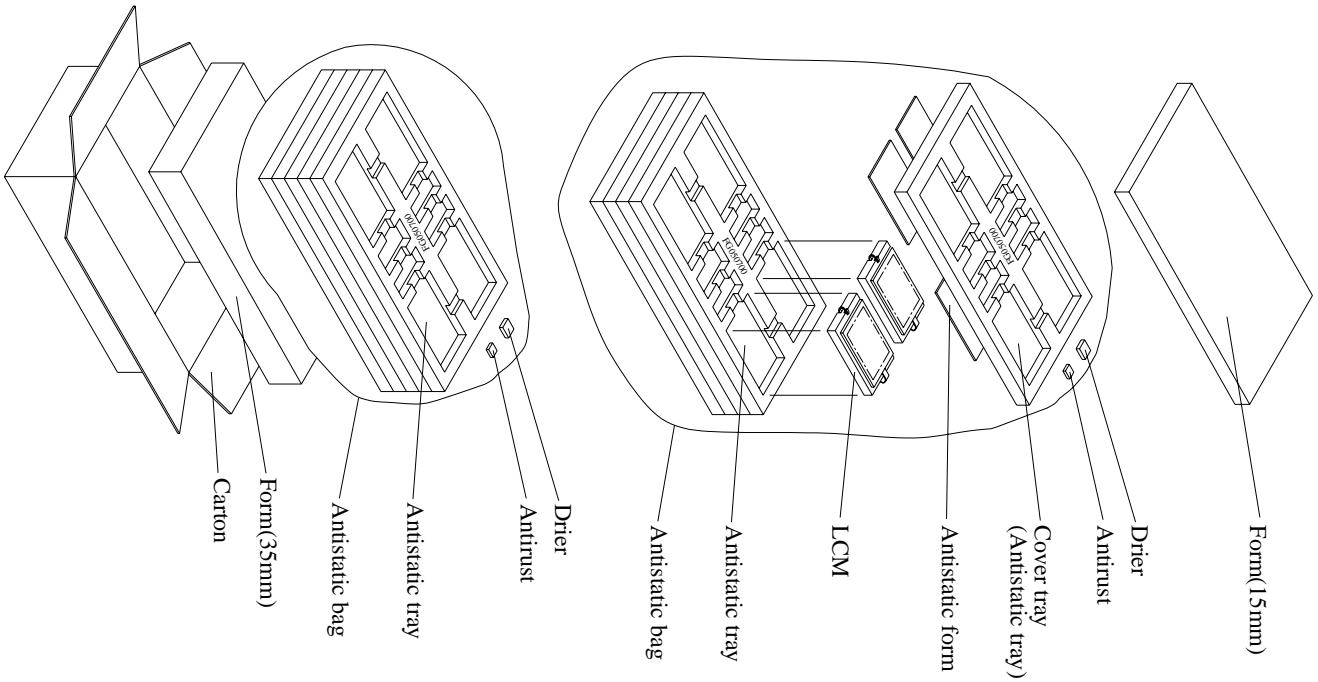

Material

1 Carton + 1 Form (15mm) + 2 Anti-static bag + 10 Anti-static tray
+ 2 Drier + 2 Antirust + 1 Form (35mm)

Total pcs

- 1 Antistatic tray = 4 pcs (modules)
- 1 Anti-static bag = 4 Anti-static tray + cover tray = 4*4 + 1*0 = 16 pcs
- 1 Carton = 2 Anti-static bag = 2*16 = 32 pcs
- 1 Carton = 32 pcs
- Carton size : 465L x 380W x 395H (mm)
- Total Weight \approx 10.2 kgw

FG050700+TP TFT LCM PACKING