



DATA IMAGE CORPORATION

TFT Module Specification

ITEM NO.: FG050700DSSWDGL2

Table of Contents

1. COVER & CONTENTS	1
2. RECORD OF REVISION	2
3. APPLICATION.....	3
4. GENERAL SPECIFICATIONS	3
5. ELECTRICAL CHARACTERISTICS	3
6. BLOCK DIAGRAM	4
7. PIN CONNECTIONS	5
8. INTERFACE SPECIFICATIONS	6
9. OPTICAL CHARACTERISTIC	10
10. QUALITY ASSURANCE	12
11. LCM PRODUCT LABEL DEFINE	13
12. PRECAUTIONS IN USE LCM	15
13. OUTLINE DRAWING	16
14. PACKAGE INFORMATION	17

Customer Companies	R&D Dept.	Q.C. Dept.	Eng. Dept.	Prod. Dept.
	<i>Jack</i>	<i>Joe</i>	<i>Ging.</i>	<i>Ben</i>
Approved by	Version:	Issued Date:	Sheet Code:	Total Pages:
	D	10/JUN/11'		17

2. RECORD OF REVISION

Rev	Date	Item	Page	Comment
A	20/AUG/09'			New Release
B	12/April/10'	14	15	Change OUTLINE DRAWING from Rev: A to Rev: B to Rev: C
C	14/DEC/10'	5.3	3	1.Modify LED dice Life Time from 25K hrs to 40K hrs & add LED circuit.
		11	13	2.Revise LCM PRODUCT LABEL DEFINE
D	10/JUN/11'	13	16	1.Modify : OUTLINE DRAWING from Rev.C to D

3. APPLICATION

Digital equipments which need color display, such as P.O.S, medical equipments and industrial equipments.

4. GENERAL SPECIFICATIONS

Parameter	Specifications	Unit
Display resolution	(320X R.G.B) (W) x 240(H)	dot
Active area	115.2(W) x 86.4(H)	mm
Screen size	5.7(Diagonal)	inch
Dot pitch	0.12(W) x 0.36(H)	mm
Color configuration	R.G.B. Stripe	
Overall dimension	144 (W) x 104.6(H) x 13(D)	mm
Weight	205	g
Surface treatment	Clear	
View Angle direction	12 o'clock	
Our components and processes are compliant to RoHS standard		

5. ELECTRICAL CHARACTERISTICS

5.1 Absolute Maximum Ratings

GND=0V

Parameter	Symbol	MIN.	MAX.	Unit	Remark
Power supply voltage	V _{CC}	-0.3	+7.0	V	
Logic input voltage	V _I	-0.3	V _{CC} +0.3	V	
Operating temperature	Top	-20	70	°C	Ambient temperature
Storage temperature	T _{st}	-30	80	°C	Ambient temperature

5.2 TFT-LCD Driving Conditions

GND=0V , Ta=25°C

Parameter	Symbol	MIN.	Typ.	MAX.	Unit	Remark
Power Supply voltage	V _{CC}	+3.0	+3.3	+3.6	V	V _{CC} =3.3V
Power Supply Current	I _{CC}		130	150	mA	
"H" level logical input voltage	V _{IH}	0.7V _{CC}	--	3.6	V	
"L" level logical input voltage	V _{IL}	0V	--	0.3V _{CC}	V	

5.3 Backlight Driving Conditions

Parameter	Symbol	Min.	Typ.	Max.	Unit	Remark
LED current	I _L	--	140	--	mA	
VLED voltage	V _L	--	10.2	10.8	V	
LED dice Life Time		--	40000	--	hr	Note 1:

Note 1: The "LED dice life time" is defined as the LED dice brightness decrease to 50% original brightness that the ambient temperature is 22 and LED dice current 20mA.

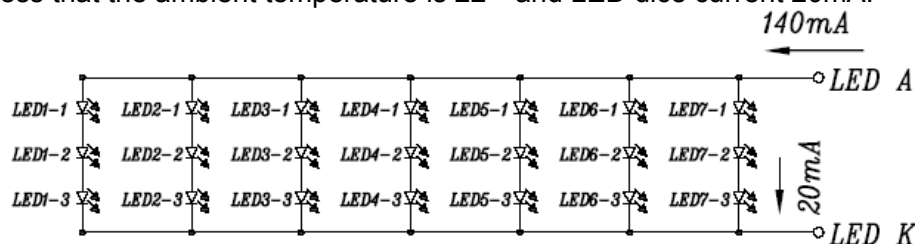

6. BLOCK DIAGRAM

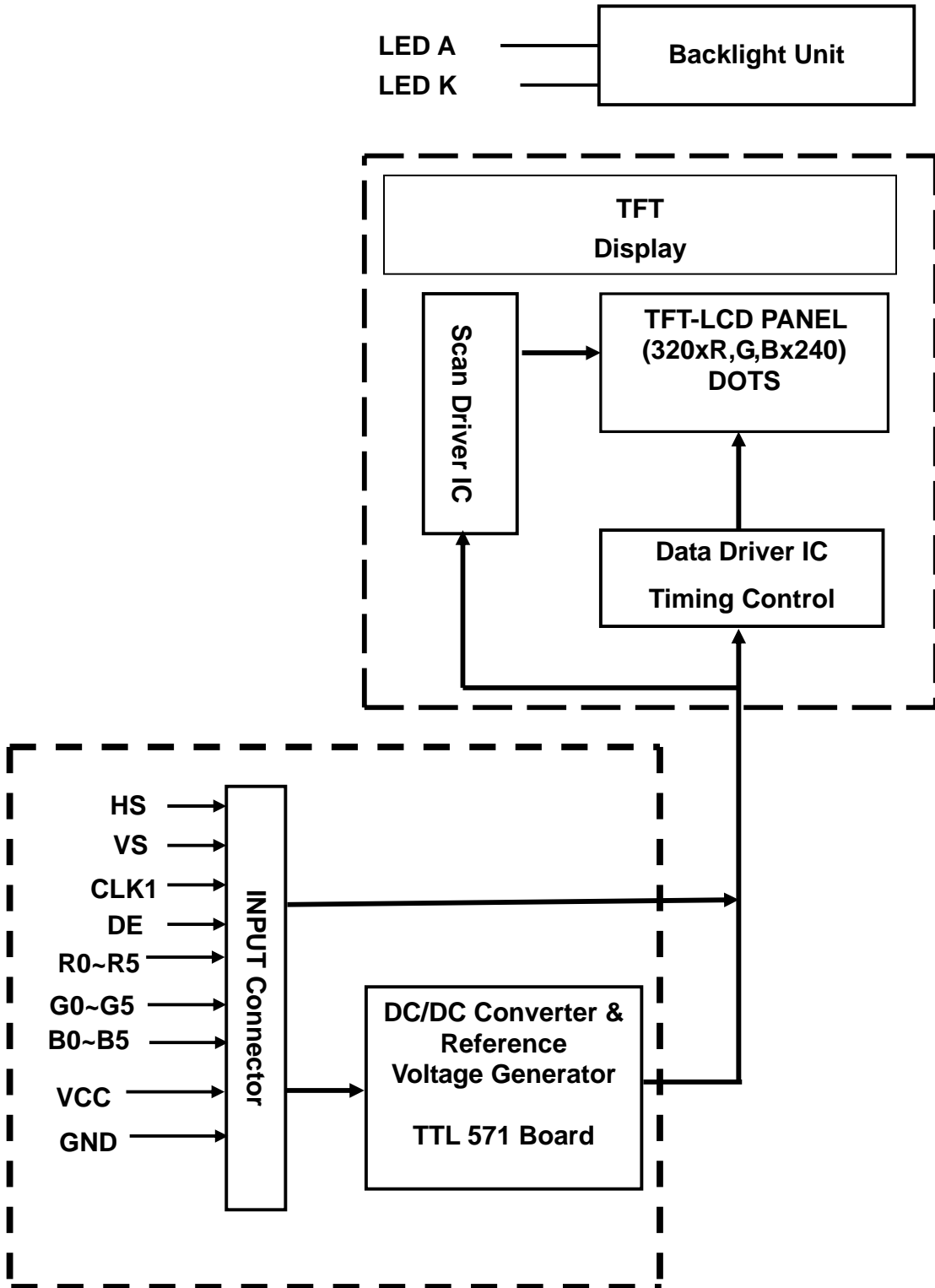

7. PIN CONNECTIONS

7.1 P1 Input Pins Connection (To TTL571 control board)

Pin No	Symbol	Function	Remark
1	GND	Ground for logic circuit	
2	CLK1	Data sampling clock	
3	HS (HSYNC)	Horizontal synchronous signal	
4	VS (VSYNC)	Vertical synchronous signal	
5	GND	Ground for logic circuit	
6	R0	Red pixel data(LSB)	
7	R1	Red pixel data	
8	R2	Red pixel data	
9	R3	Red pixel data	
10	R4	Red pixel data	
11	R5	Red pixel data(MSB)	
12	GND	Ground for logic circuit	
13	G0	Green pixel data(LSB)	
14	G1	Green pixel data	
15	G2	Green pixel data	
16	G3	Green pixel data	
17	G4	Green pixel data	
18	G5	Green pixel data(MSB)	
19	GND	Ground for logic circuit	
20	B0	Blue pixel data(LSB)	
21	B1	Blue pixel data	
22	B2	Blue pixel data	
23	B3	Blue pixel data	
24	B4	Blue pixel data	
25	B5	Blue pixel data(MSB)	
26	GND	Ground for logic circuit	
27	DE	Data Enable (connected to GND, if sync mode)	
28	VCC	Power Supply : +3.3V	
29	VCC	Power Supply : +3.3V	
30	R/L	Horizontal display mode select signal Left / Right Scan control input	*2
31	U/D	Vertical display mode select signal Up / Down Scan control input	*2
32	NC	No Connection	
33	GND	Ground for logic circuit	

*1 The horizontal display start timing is settled in accordance with a rising timing of DE signal.
Don't keep DE "High" during operation.

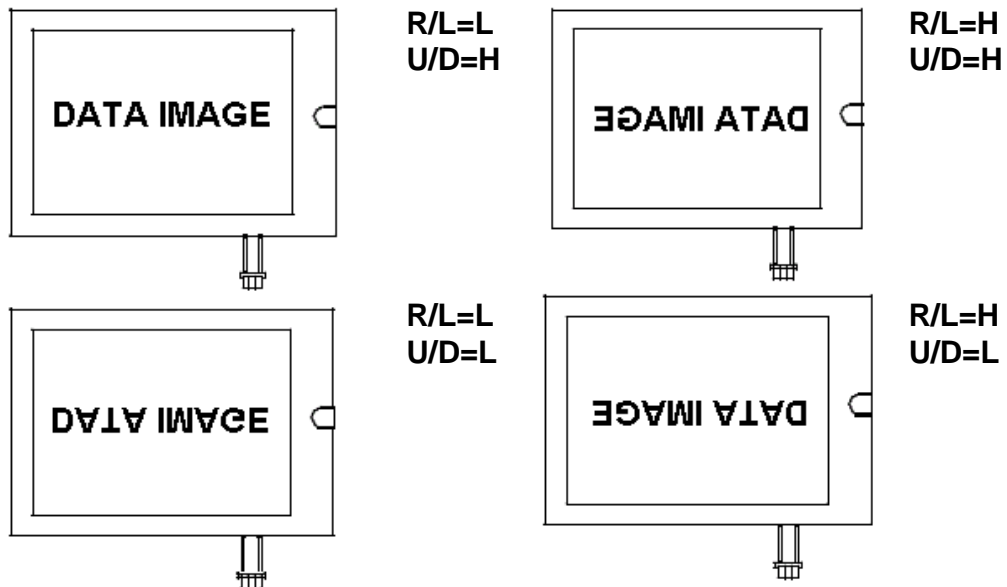

8. INTERFACE SPECIFICATIONS

8.1 Input Signal Timing Specifications

Parameter		Symbol	MIN.	TYP.	MAX.	Unit	Remarks
CLK	Frequency	1/Tc		7.21		MHz	
	Duty ratio	Th/Tc	40	50	60	%	
DATA	Setup time	Tds	12			ns	
	Hold time	Tdh	12			ns	
Horizontal synchronizing	Period	TH	--	453	--	Clock	
	Pulse width	THp	--	31	--	Clock	
	Horizontal period	THd	--	320	--	Clock	
	Blank porch	THb	--	69	--	Clock	
	Front porch	THf	--	33	--	Clock	
Vertical synchronizing	Period	TV	--	267	--	Line	
	Pulse width	TVp	--	6	--	Line	
	Vertical period	TVd	--	240	--	Line	
	Blank porch	TVb	--	18	--	Line	
	Front porch	TVf	--	3	--	Line	

Note:

- ◇ In case of using the slow frequency, the deterioration of display flicker etc may occur.
- ◇ The timing characteristics are basically fixed as above.

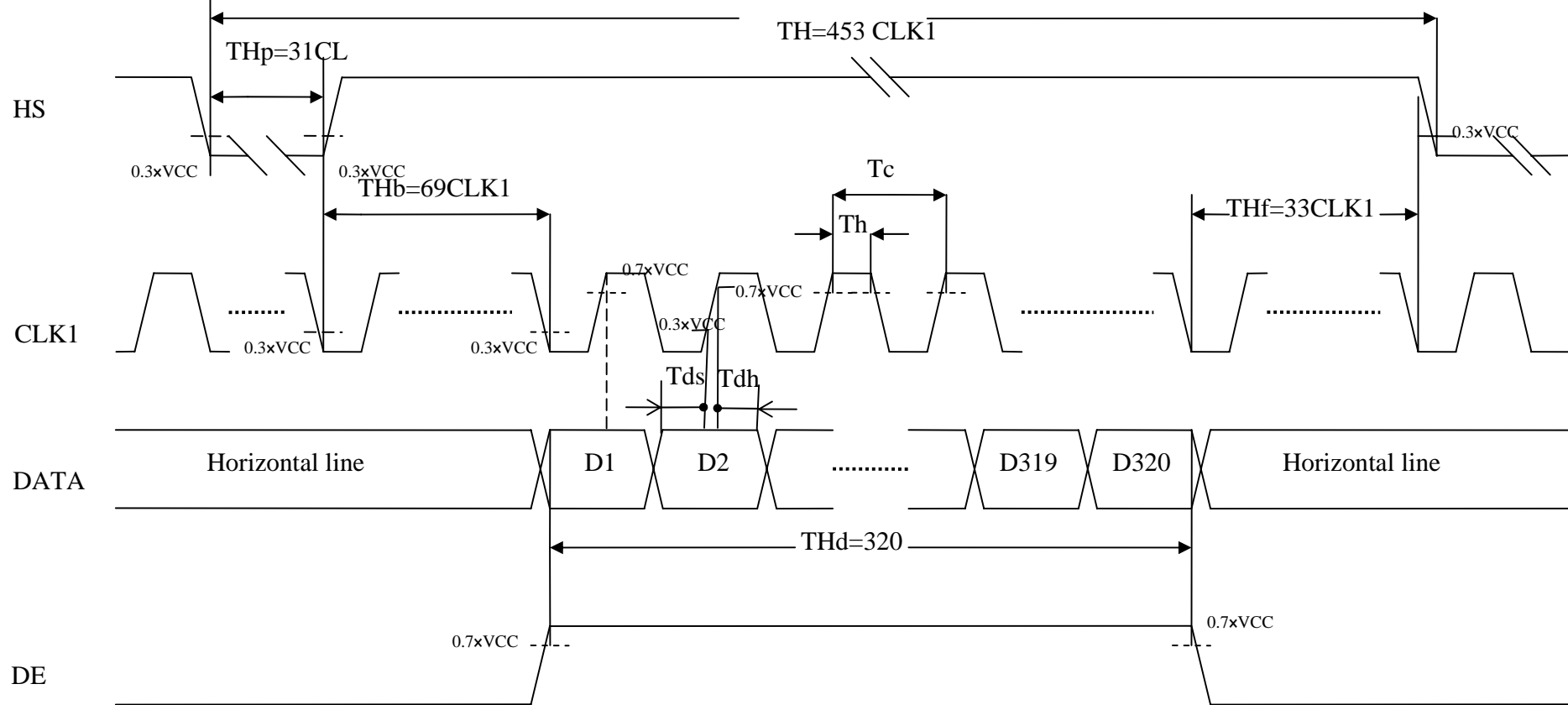

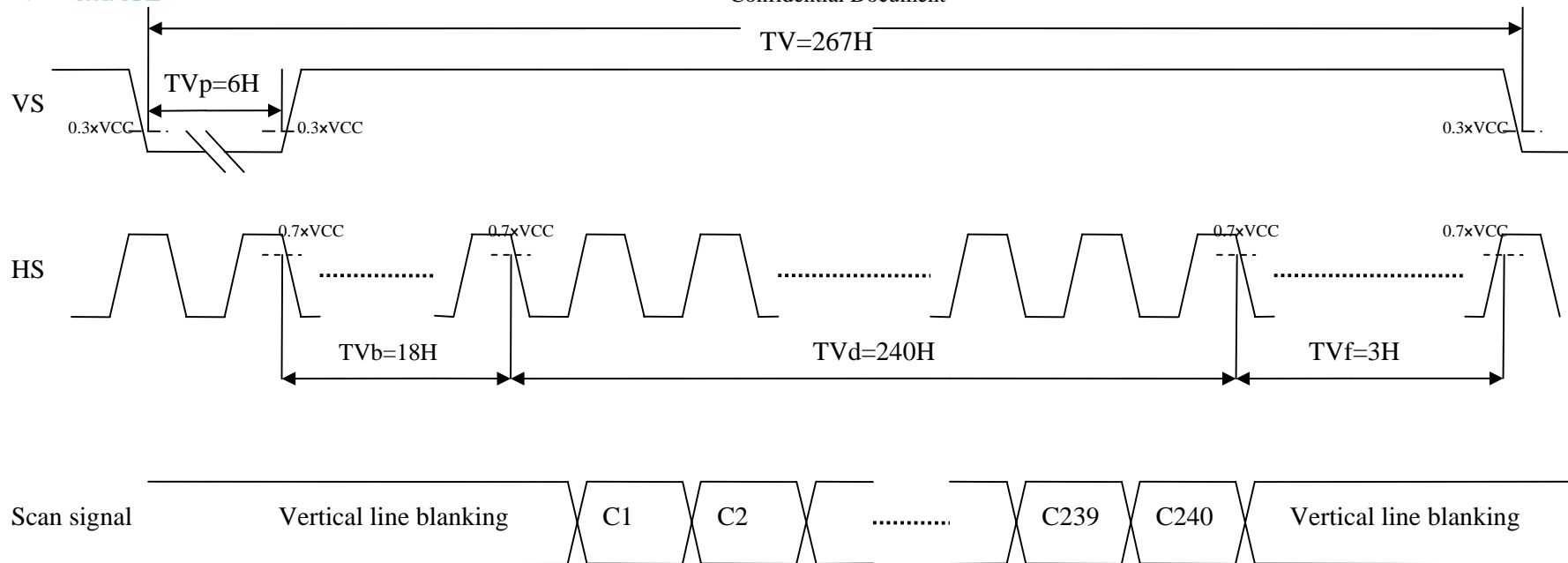

8.2 Power Off/On Sequence Timing

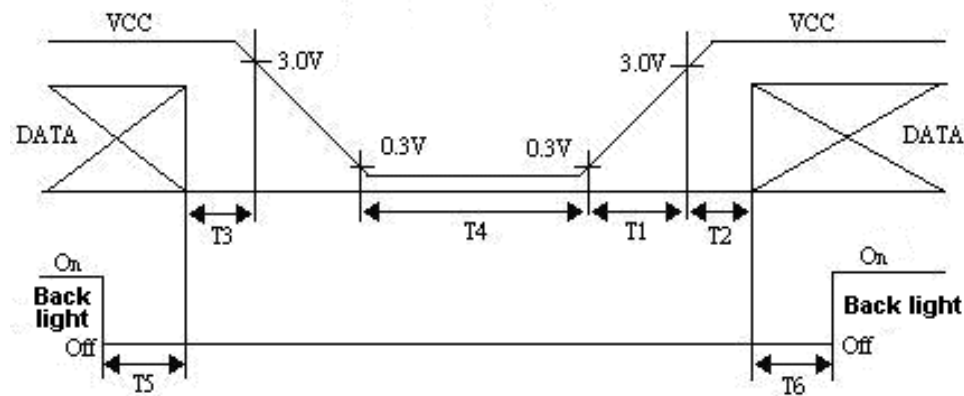

Timing Specifications:

- $0 < T1 \leq 15mS$
- $T2 > 0.5S$
- $0 < T3 \leq 0.1S$
- $T4 > 1S$
- $T5 > 0.1S$
- $T6 > 0.1S$

8.3 Color Data Input Assignment

		Data Signal																	
		Red					Green					Blue							
Color		R0	R1	R2	R3	R4	R5	G0	G1	G2	G3	G4	G5	B0	B1	B2	B3	B4	B5
Basic Colors	Black	0	0	0	0	0	0	0	0	0	0	0	0	0	0	0	0	0	0
	Red	1	1	1	1	1	1	0	0	0	0	0	0	0	0	0	0	0	0
	Green	0	0	0	0	0	0	1	1	1	1	1	1	0	0	0	0	0	0
	Blue	0	0	0	0	0	0	0	0	0	0	0	0	1	1	1	1	1	1
	Cyan	0	0	0	0	0	0	1	1	1	1	1	1	1	1	1	1	1	1
	Magenta	1	1	1	1	1	1	0	0	0	0	0	0	1	1	1	1	1	1
	Yellow	1	1	1	1	1	1	1	1	1	1	1	1	0	0	0	0	0	0
	White	1	1	1	1	1	1	1	1	1	1	1	1	1	1	1	1	1	1
Gray Scale of Red	Red(0) / Dark	0	0	0	0	0	0	0	0	0	0	0	0	0	0	0	0	0	0
	Red(1)	0	0	0	0	0	1	0	0	0	0	0	0	0	0	0	0	0	0
	Red(2)	0	0	0	0	1	0	0	0	0	0	0	0	0	0	0	0	0	0
	:	:	:	:	:	:	:	:	:	:	:	:	:	:	:	:	:	:	:
	:	:	:	:	:	:	:	:	:	:	:	:	:	:	:	:	:	:	:
	Red(61)	1	1	1	1	0	1	0	0	0	0	0	0	0	0	0	0	0	0
	Red(62)	1	1	1	1	1	0	0	0	0	0	0	0	0	0	0	0	0	0
	Red(63)	1	1	1	1	1	1	0	0	0	0	0	0	0	0	0	0	0	0
Gray Scale of Green	Green(0)/ Dark	0	0	0	0	0	0	0	0	0	0	0	0	0	0	0	0	0	0
	Green(1)	0	0	0	0	0	0	0	0	0	0	0	1	0	0	0	0	0	0
	Green(2)	0	0	0	0	0	0	0	0	0	0	1	0	0	0	0	0	0	0
	:	:	:	:	:	:	:	:	:	:	:	:	:	:	:	:	:	:	:
	:	:	:	:	:	:	:	:	:	:	:	:	:	:	:	:	:	:	:
	Green(61)	0	0	0	0	0	0	1	1	1	1	0	1	0	0	0	0	0	0
	Green(62)	0	0	0	0	0	0	1	1	1	1	1	0	0	0	0	0	0	0
	Green(63)	0	0	0	0	0	0	1	1	1	1	1	1	0	0	0	0	0	0
Gray Scale of Blue	Blue(0)/ Dark	0	0	0	0	0	0	0	0	0	0	0	0	0	0	0	0	0	0
	Blue (1)	0	0	0	0	0	0	0	0	0	0	0	0	0	0	0	0	0	1
	Blue (2)	0	0	0	0	0	0	0	0	0	0	0	0	0	0	0	0	1	0
	:	:	:	:	:	:	:	:	:	:	:	:	:	:	:	:	:	:	:
	:	:	:	:	:	:	:	:	:	:	:	:	:	:	:	:	:	:	:
	Blue (61)	0	0	0	0	0	0	0	0	0	0	0	0	1	1	1	1	0	1
	Blue (62)	0	0	0	0	0	0	0	0	0	0	0	0	1	1	1	1	1	0
	Blue (63)	0	0	0	0	0	0	0	0	0	0	0	0	1	1	1	1	1	1

Correspondence between Data and Display Position

	S960	S959	S958	S957	S956	S955	S954	S953	-----	S002	S001
C001	B320	G320	R320	B319	G319	R319	B318	G318		G001	R001
C240	B320	G320	R320	B319	G319	R319	B318	G318		G001	R001

9. OPTICAL CHARACTERISTIC

9-1. Specification:

Item	Symbol	Condition	Min.	Typ.	Max.	Unit	Remark	
Response time	Rise	$\theta=0^\circ$	-	15	30	ms	Note 4	
	Fall		-	35	50	ms		
Contrast ratio	CR	At optimized viewing angle	300	350			Note 5	
Viewing angle	Top	θ_{y+}	CR \geq 5	60	70	-	Deg.	Note 6
	Bottom	θ_{y-}		40	50	-		
	Left	θ_{x-}		60	70	-		
	Right	θ_{x+}		60	70	-		
Brightness		$\theta=0^\circ$	360	400	--	cd/m ²	Note 7	
Uniformity			75	--		%	Note 9	
White chromaticity	X	$\theta=0^\circ$	0.25	0.30	0.35		Note 7	
	y		0.30	0.35	0.40			

Note 1: Ambient temperature =25°C. LED current = 140 mA..

Note 2: To be measured in the dark room.

Note 3: To be measured on the center area of panel with a viewing cone of 1° by Topcon luminance meter BM-7A, after 10 minutes operation.

Note 4: Definition of response time:

The output signals of photo-detector are measured when the input signals are changed from "white" to "black"(rising time) and from "black" to "white"(falling time), respectively. The response time is defined as the time interval between the 10% and 90% of amplitudes. Refer to figure as shown below.

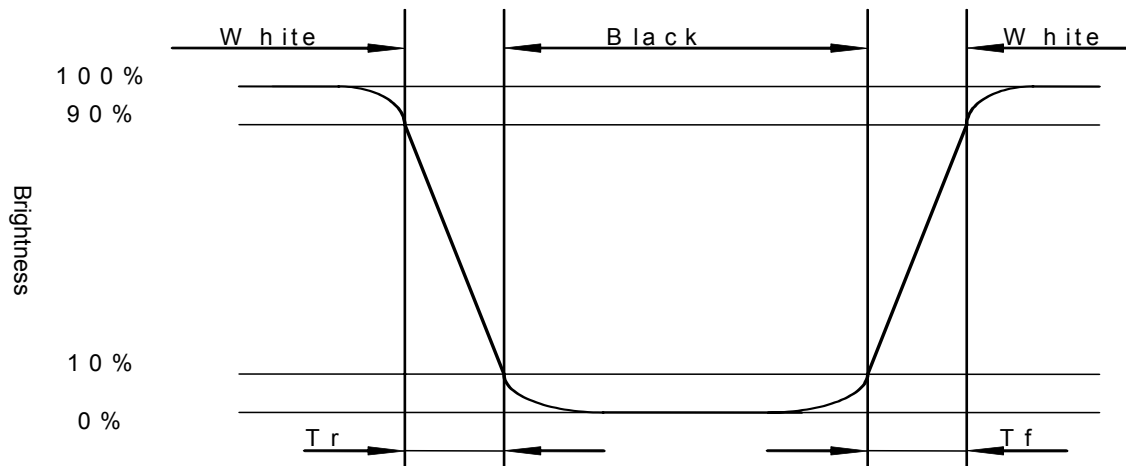

Note5: Definition of contrast ratio:

Contrast ratio is calculated with the following formula.

$$\text{Contrast ratio (CR)} = \frac{\text{Photo-detector output when LCD is at "White" state}}{\text{Photo-detector output when LCD is at "Black" state}}$$

Note 6. Definition of viewing angle:
Refer to figure as below.

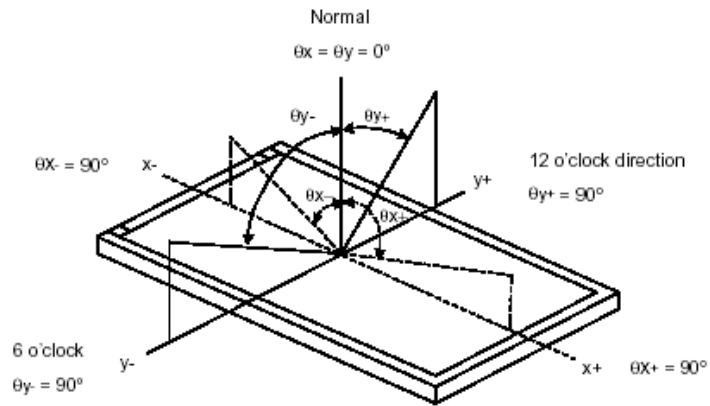

Note 7. Measured at the center area of the panel when all the input terminals of LCD panel are electrically opened.

Note8: The method of optical measurement:

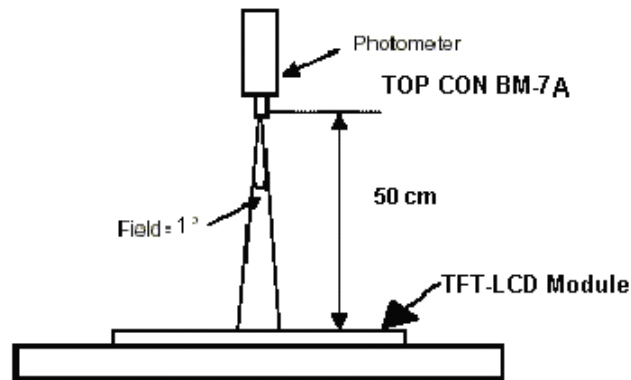

Note9: Definition of Brightness Uniformity (Buni):

Luminance Measuring Points

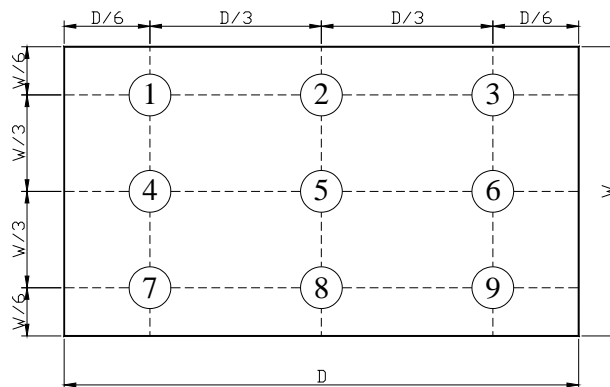

$$B\text{-uni} = \frac{\text{Minimum luminance of 9 points}}{\text{Maximum luminance of 9 points}}$$

10. QUALITY ASSURANCE

10.1 Test Condition

10.1.1 Temperature and Humidity(Ambient Temperature)

Temperature : $25 \pm 5^{\circ}\text{C}$

Humidity : $65 \pm 5\%$

10.1.2 Operation

Unless specified otherwise, test will be conducted under function state.

10.1.3 Container

Unless specified otherwise, vibration test will be conducted to the product itself without putting it in a container.

10.1.4 Test Frequency

In case of related to deterioration such as shock test. It will be conducted only once.

10.1.5 Test Method

No.	Reliability Test Item & Level	Test Level
1	High Temperature Storage Test	T=80°C,240hrs
2	Low Temperature Storage Test	T=-30°C,240hrs
3	High Temperature Operation Test	T=70°C,240hrs
4	Low Temperature Operation Test	T=-20°C,240hrs
5	High Temperature and High Humidity Operation Test	T=60°C,90% RH,240hrs
6	Thermal Cycling Test (No operation)	-30°C → +25°C → +80°C,200 Cycles 30 min 5min 30 min
7	Vibration Test (No operation)	Frequency:0 ~ 55 Hz Amplitude:1.5 mm Sweep Time:11min Test Period:6 Cycles for each Direction of X,Y,Z
8	Electrostatic Discharge Test (No operation)	150pF,330Ω Air:± 15KV;Contact: ± 8KV 10 times/point;4 points/panel face

11. LCM PRODUCT LABEL DEFINE

Product Label style:

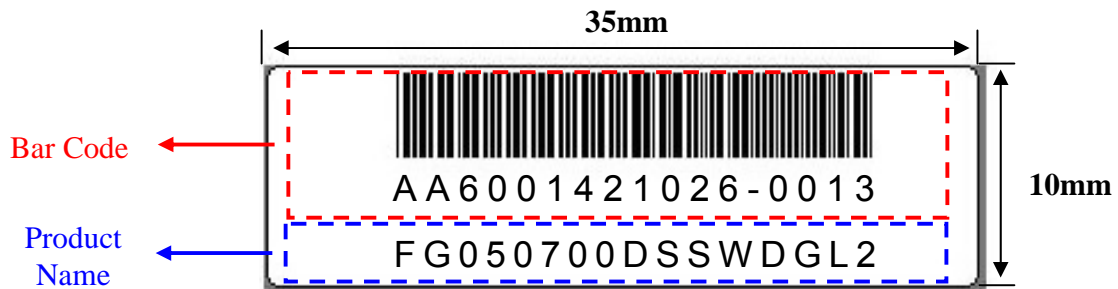

BarCode Define:

A A 6 0014 2 10 26-0013

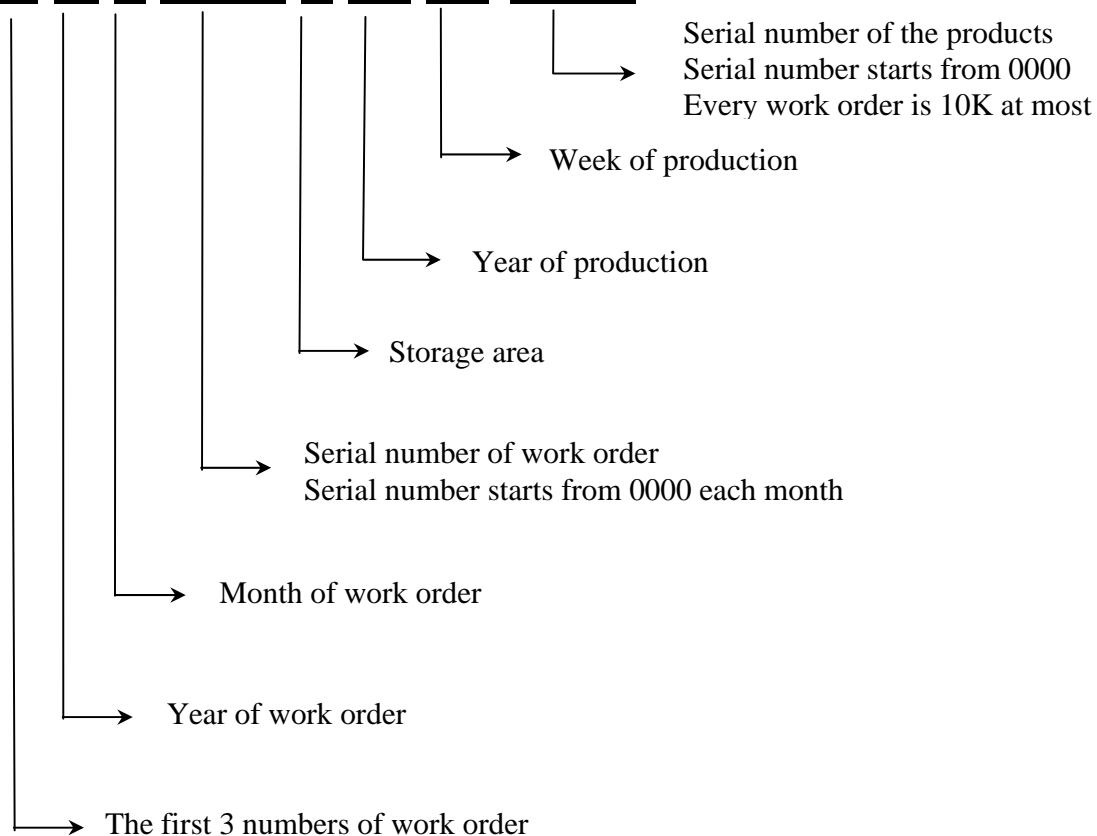

Product Name Define:

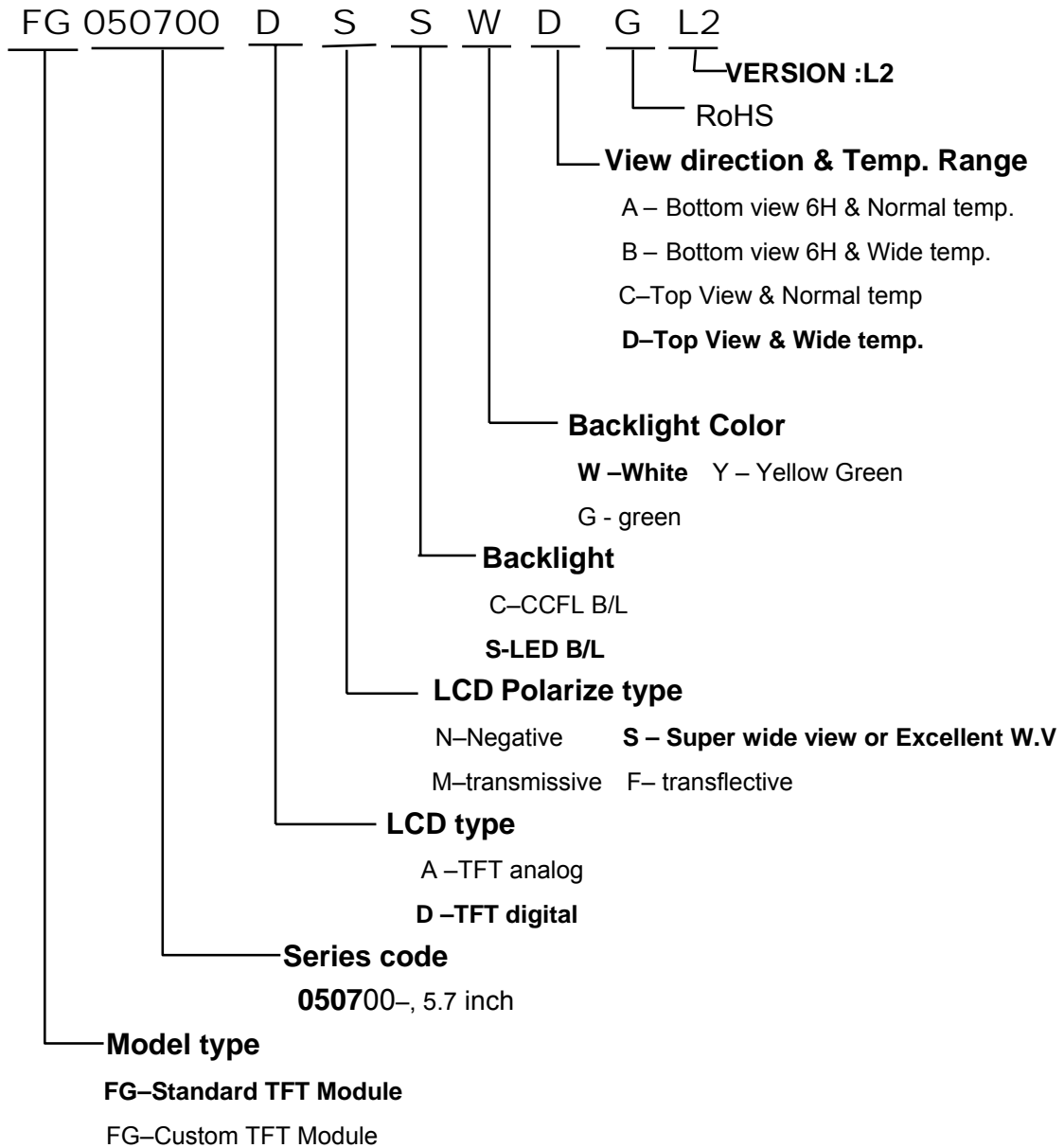

12. PRECAUTIONS IN USE LCM

1. LIQUID CRYSTAL DISPLAY (LCD)

LCD is made up of glass, organic sealant, organic fluid, and polymer based polarizers. The following precautions should be taken when handling,

- (1). Keep the temperature within range of use and storage. Excessive temperature and humidity could cause polarization degradation, polarizer peel off or bubble.
- (2). Do not contact the exposed polarizers with anything harder than an HB pencil lead. To clean dust off the display surface, wipe gently with cotton, chamois or other soft material soaked in petroleum benzin.
- (3). Wipe off saliva or water drops immediately. Contact with water over a long period of time may cause polarizer deformation or color fading, while an active LCD with water condensation on its surface will cause corrosion of ITO electrodes.
- (4). Glass can be easily chipped or cracked from rough handling, especially at corners and edges.
- (5). Do not drive LCD with DC voltage.

2. Liquid Crystal Display Modules

2.1 Mechanical Considerations

LCM are assembled and adjusted with a high degree of precision. Avoid excessive shocks and do not make any alterations or modifications. The following should be noted.

- (1). Do not tamper in any way with the tabs on the metal frame.
- (2). Do not modify the PCB by drilling extra holes, changing its outline, moving its components or modifying its pattern.
- (3). Do not touch the elastomer connector, especially insert an backlight panel (for example, EL).
- (4). When mounting a LCM make sure that the PCB is not under any stress such as bending or twisting. Elastomer contacts are very delicate and missing pixels could result from slight dislocation of any of the elements.
- (5). Avoid pressing on the metal bezel, otherwise the elastomer connector could be deformed and lose contact, resulting in missing pixels.

2.2. Static Electricity

LCM contains CMOS LSI's and the same precaution for such devices should apply, namely

- (1). The operator should be grounded whenever he/she comes into contact with the module. Never touch any of the conductive parts such as the LSI pads, the copper leads on the PCB and the interface terminals with any parts of the human body.
- (2). The modules should be kept in antistatic bags or other containers resistant to static for storage.
- (3). Only properly grounded soldering irons should be used.
- (4). If an electric screwdriver is used, it should be well grounded and shielded from commutator sparks.

- (5) The normal static prevention measures should be observed for work clothes and working benches; for the latter conductive (rubber) mat is recommended.
- (6). Since dry air is inductive to statics, a relative humidity of 50-60% is recommended.

2.3 Soldering

- (1). Solder only to the I/O terminals.
- (2). Use only soldering irons with proper grounding and no leakage.
- (3). Soldering temperature : $280^{\circ}\text{C} \pm 10^{\circ}\text{C}$
- (4). Soldering time: 3 to 4 sec.
- (5). Use eutectic solder with resin flux fill.
- (6). If flux is used, the LCD surface should be covered to avoid flux spatters. Flux residue should be removed after wards.

2.4 Operation

- (1). The viewing angle can be adjusted by varying the LCD driving voltage V0.
- (2). Driving voltage should be kept within specified range; excess voltage shortens display life.
- (3). Response time increases with decrease in temperature.
- (4). Display may turn black or dark blue at temperatures above its operational range; this is (however not pressing on the viewing area) may cause the segments to appear "fractured".
- (5). Mechanical disturbance during operation (such as pressing on the viewing area) may cause the segments to appear "fractured".

2.5 Storage

If any fluid leaks out of a damaged glass cell, wash off any human part that comes into contact with soap and water. Never swallow the fluid. The toxicity is extremely low but caution should be exercised at all the time.

2.6 Limited Warranty

Unless otherwise agreed between DATA IMAGE and customer, DATA IMAGE will replace or repair any of its LCD and LCM which is found to be defective electrically and visually when inspected in accordance with DATA IMAGE acceptance standards, for a period on one year from date of shipment. Confirmation of such date shall be based on freight documents. The warranty liability of DATA IMAGE is limited to repair and/or replacement on the terms set forth above. DATA IMAGE will not responsible for any subsequent or consequential events.

Confidential Document
13. OUTLINE DRAWING

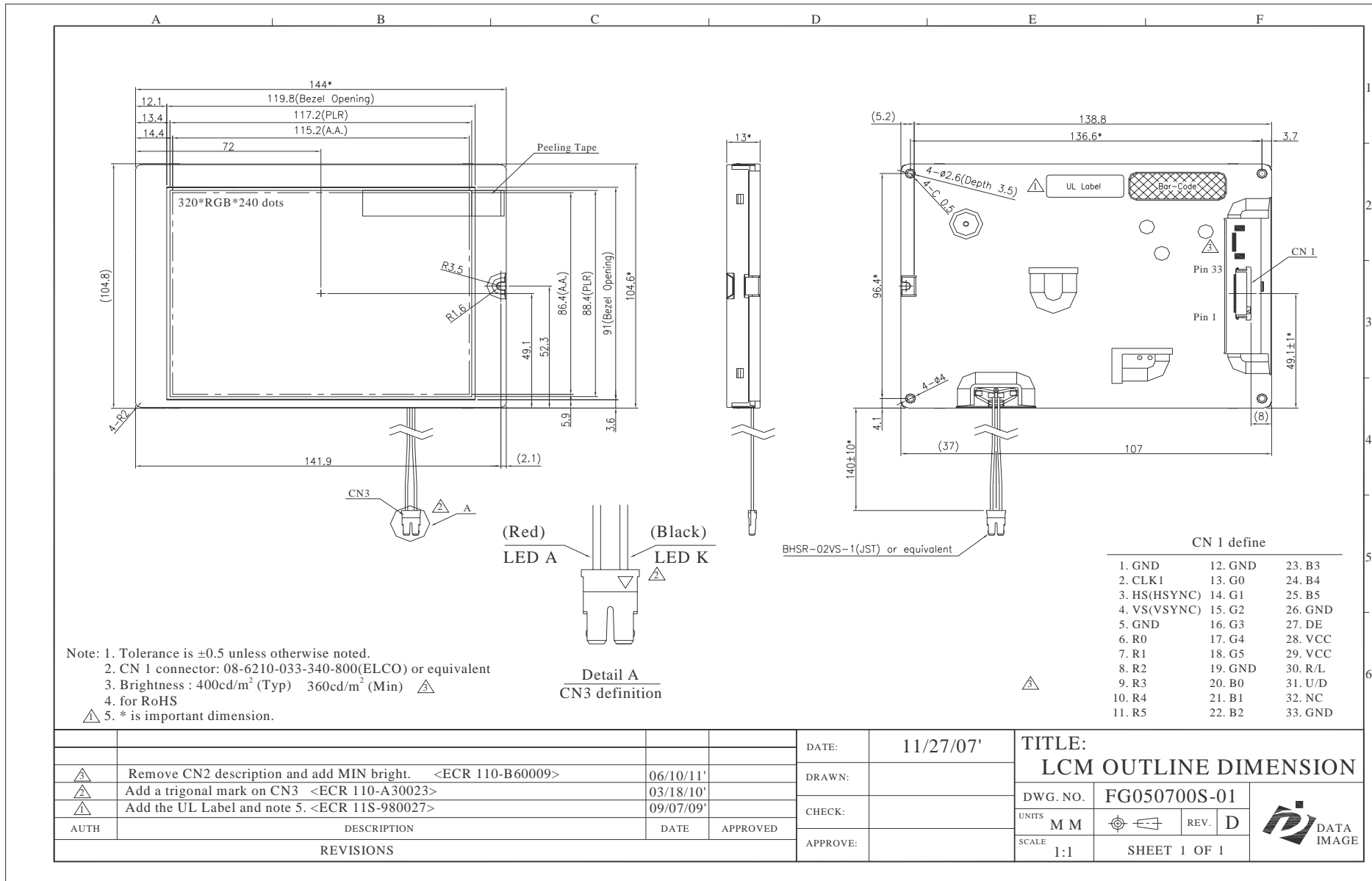

14. PACKAGE INFORMATION

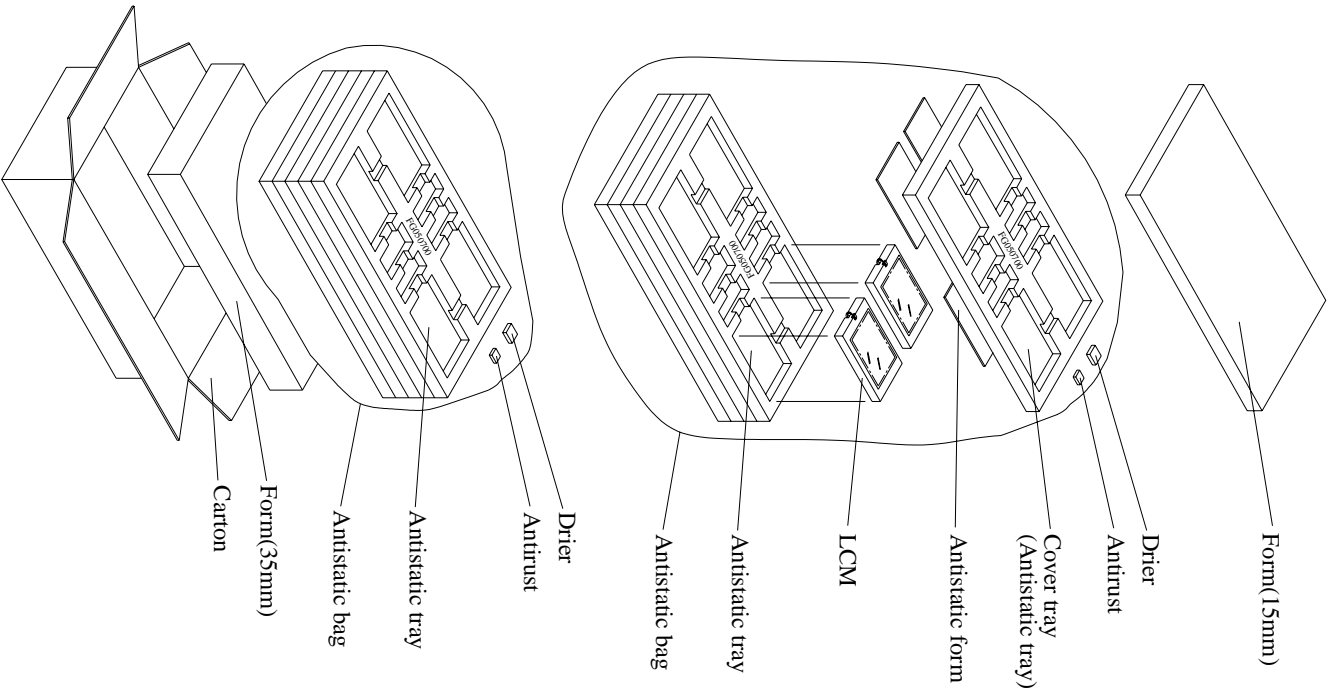

Material

1 Carton + 1 Form (15mm) + 2 Anti-static bag + 10 Anti-static tray
+ 2 Drier + 2 Antirust + 1 Form (35mm)

Total pcs

- 1 Antistatic tray = 4 pcs (modules)
- 1 Anti-static bag = 4 Anti-static tray + cover tray = 4*4 + 1*0 =16 pcs
- 1 Carton = 2 Anti-static bag = 2*16 = 32 pcs
- 1 Carton = 32 pcs
- Carton size : 465L x 380W x 395H (mm)
- Total Weight ±9.0 kgw

FG050700 TFT LCM PACKING