



DATA IMAGE CORPORATION

TFT Module Specification

PRELIMINARY

ITEM NO.: FG1004B2DSSWAGL1

Table of Contents

1. COVER & CONTENTS	1
2. RECORD OF REVISION	2
3. SUMMARY.....	3
4. FEATURES.....	3
5. GENERAL SPECIFICATIONS	3
6. ABSOLUTE MAXIMUM RATINGS	3
7. ELECTRICAL CHARACTERISTICS	4
8. POWRE SEQUENCE.....	5
9. AC CHARACTERISTICS.....	5
10. OPTICAL CHARACTERISTIC	8
11. INTERFACE.....	10
12. BLOCK DIAGRAM	11
13. QUALITY ASSURANCE	12
14. LCM PRODUCT LABEL DEFINE	13
15. PRECAUTIONS IN USE LCM	15
16. OUTLINE DRAWING	16
17. PACKAGE INFORMATION.....	17

Customer Companies	R&D Dept.	Q.C. Dept.	Eng. Dept.	Prod. Dept.
	JACK	JOE	GARY	KEN
Approved by	Version:	Issued Date:	Sheet Code:	Total Pages:
	1	27/APR/11'		17

2. RECORD OF REVISION

Rev	Date	Item	Page	Comment
1	27/APR/11'			Initial PRELIMINARY

3. SUMMARY

The module is a transmissive type color active matrix liquid crystal display (LCD), which uses amorphous thin film transistor (TFT) as switching devices. This panel has a 10.4 inches diagonally measured active display area with SVGA (800 RGB X 600) resolution. The following describes the features of this product.

4. FEATURES

- 10.4" (diagonal) inch configuration
- SVGA (800 X 600 pixels) resolution

5. GENERAL SPECIFICATIONS

Parameter	Specifications	Unit
Screen Size	10.4 (Diagonal)	inch
Display Format	Normally white, Transmissive type	
Number of Pixel	800 RGB X 600	dot
Active Area	211.2(H) x 158.4(V)	mm
Pixel Pitch	88(H) x 264 (V)	um
Dot Configuration	RGB-Stripe	
Interface	LVDS	
View Angle direction (Gray inversion)	6 o'clock	
Outline Dimension	228.4(W) x 175.4(H) x 10.5(D)	mm
Weight	TBD	g
Temperature Range	Operation	-10~50
	Storage	-20~60

6. ABSOLUTE MAXIMUM RATINGS

GND=0V

Parameter	Symbol	MIN.	MAX.	Unit	Remark
Power supply voltage	Vcc	-0.3	5.0	V	
Logic input voltage	VI	-0.3	V _{CC} +0.3	V	
Operating temperature	Top	-10	50	°C	
Storage temperature	Tst	-20	60	°C	

7. ELECTRICAL CHARACTERISTICS

GND=0V, f_{CLK}=40MHz, T_a=25

Parameter	Symbol	MIN.	Typ.	MAX.	Unit	Remark
Power Supply voltage for LCD	V _{CC}	+3.0	+3.3	+3.6	V	
Power Supply Current for LCD	I _{CC}		185	250	mA	V _{CC} =3.3V
Power Supply voltage for LED	V _{DD}	4.5	5	5.5	V	
Power Supply Current for LED	I _{DD}		530	700	mA	V _{DD} =5.0V
Ripple voltage	V _{RF}	-	-	100	mV _{P-P}	
“H” level logical input voltage	V _{IH}	0.7V _{CC}	--	V _{CC}	V	
“L” level logical input voltage	V _{IL}	0	--	0.3V _{CC}	V	
ADJ frequency		19K	20K	21K	Hz	
ADJ input voltage	V _{IH}	3.0	-	3.3	V	
	V _{IL}	0	-	0.3	V	
LED dice life time		10,000		-	Hr	Note 1
Differential Input High Threshold	V _{TH}	-	-	100	[mV]	V _{CM} =1.2V
Differential input Low Threshold	V _{TL}	-100	-	-	[mV]	V _{CM} =1.2V
Input Differential Voltage	V _{ID}	100	400	600	[mV]	
Differential Input Common Mode Voltage	V _{CM}	1.1	1.2	1.45	[V]	V _{TH} /V _{TL} =±100mV

Note 1: The “LED dice life time” is defined as the brightness decrease to 50% original brightness that the ambient temperature is 18 ~28 and LED dice current=20mA.

Note 2: LVDS Signal Waveform.

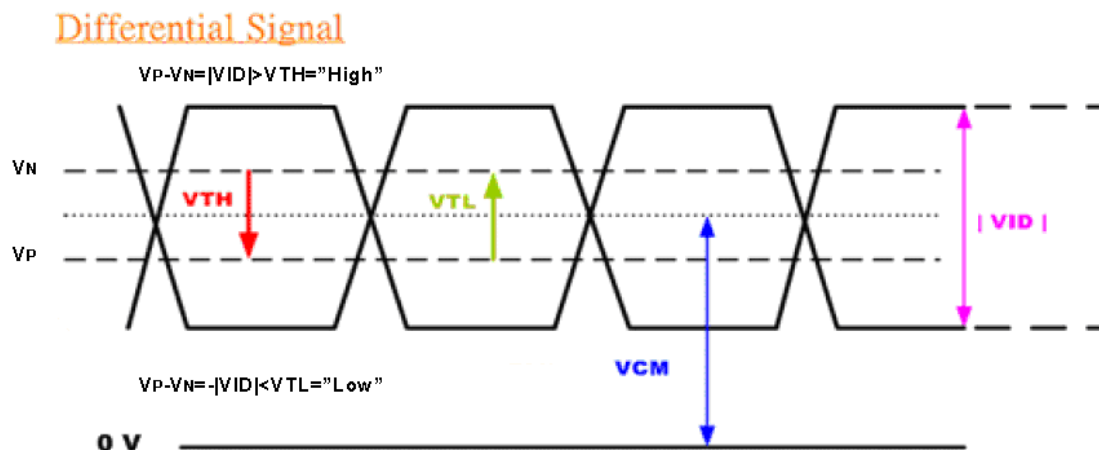

8. Power sequence

The LCD panel power ON/OFF sequence is as below

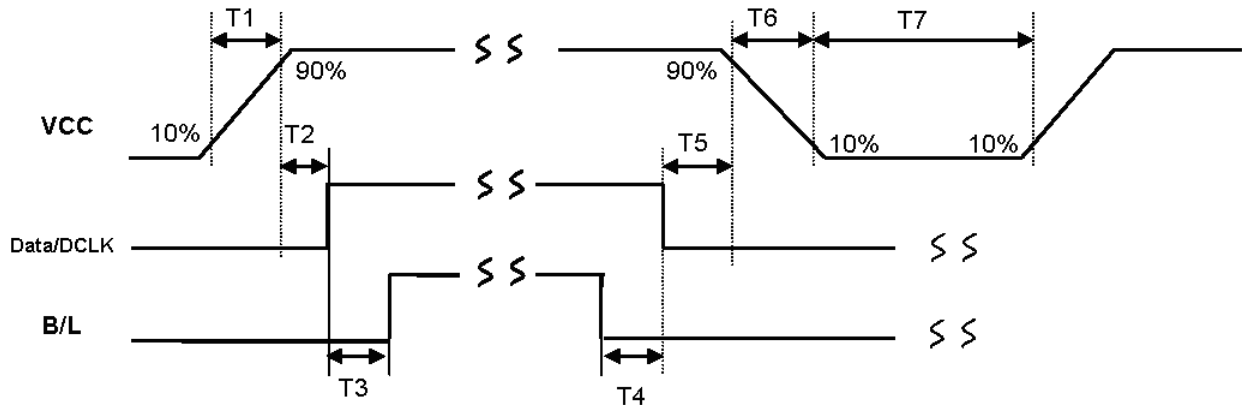

	Min.	Typ.	Max.	Unit
T1			20	ms
T2	50		200	ms
T3	200			ms
T4	200			ms
T5	16		50	ms
T6			20	ms
T7	1000			ms

9. AC CHARACTERISTICS

9.1 AC Electrical characteristic

Parameter	Symbol	Min.	Typ.	Max.	Unit
Data Setup Time	Tdsu	8			ns
Data Hold Time	Tdhd	8			ns
DE Setup Time	Tesu	8			ns
DE Hold Time	Tehd	8			ns

9.2 Data timing

Parameter	Symbol	MIN.	TYP.	MAX.	Unit
DCLK frequency	F _{CPH}	35	40	45	MHz
DCLK period	T _{CPH}	23	25	28.5	ns
DCLK pulse duty	T _{CWH}	40	50	60	%
DE period	T _{DEH} +T _{DEL}	862	1056	1200	T _{CPH}
DE pulse width	T _{DH}	800	800	800	T _{CPH}
DE frame blanking	T _{DEB}	24	35	100	T _{DEH} +T _{DEL}
DE frame width	T _{DE}	600	600	600	T _{DEH} +T _{DEL}

9.3 Timing wave form

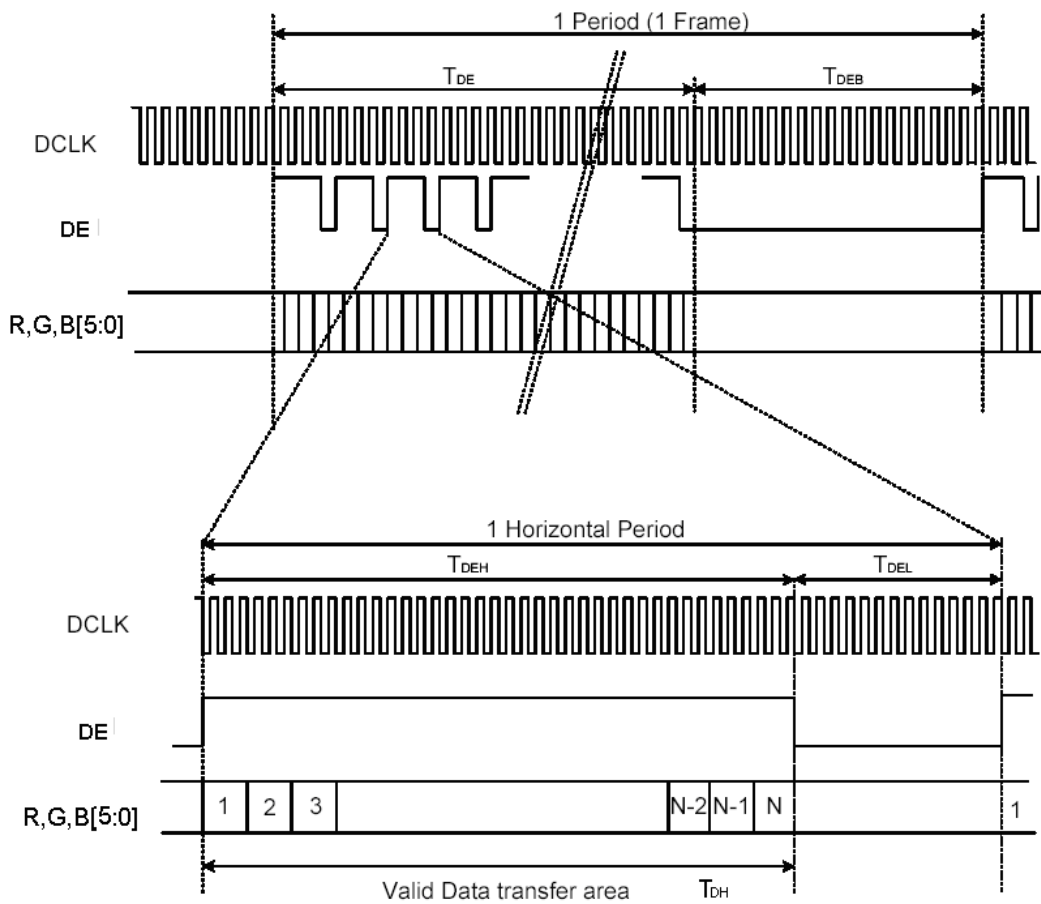
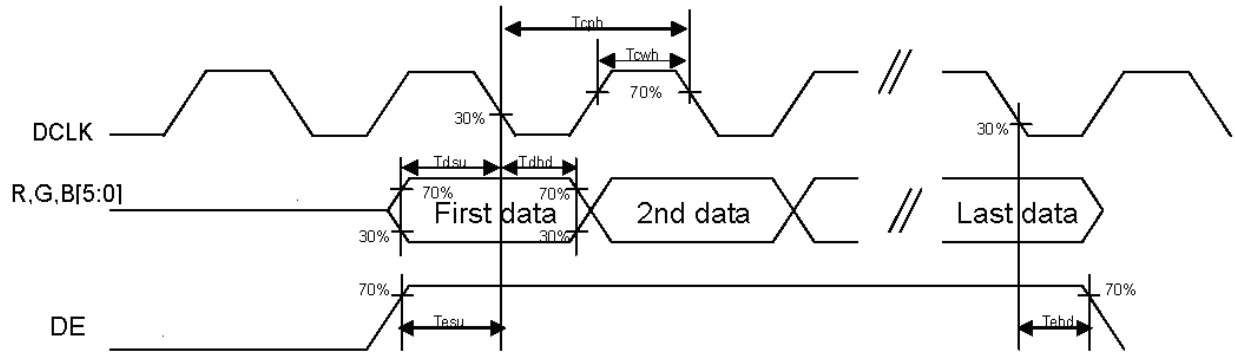

N=800

Figure 1 DE Mode Data Format

9.4 LVDS Input Data Mapping

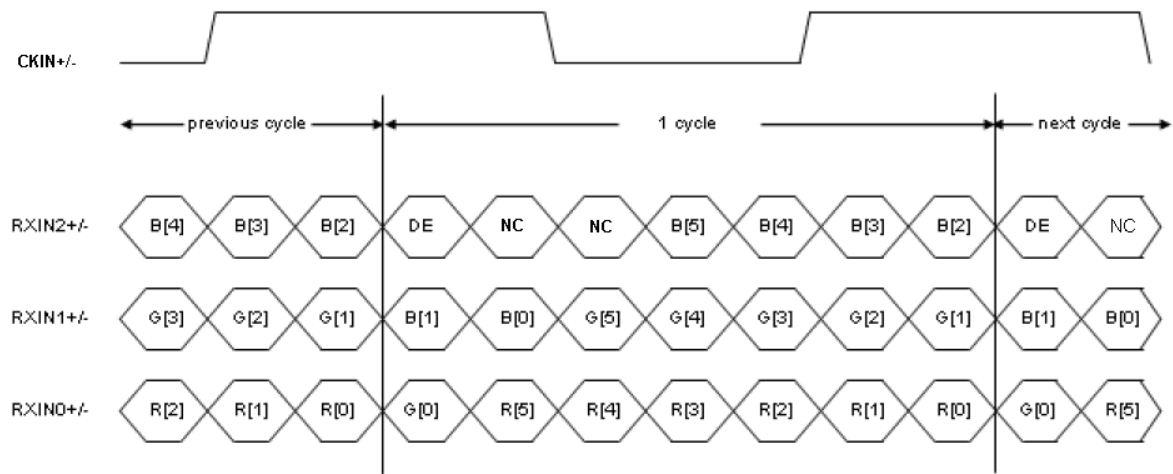

10. OPTICAL CHARACTERISTIC

Ta=25

Item	Symbol	Condition	Min.	Typ.	Max.	Unit	Note	
Response time	Tr	Viewing normal angle $\Theta=\Psi=0^\circ$, Center of Display	-	5	10	ms	Note:3	
	Tf		-	15	20	ms		
Contrast ratio	CR		300	500	-	-	Note:4	
Color Chromaticity	White		Wx	0.26	0.31	0.36	-	Note:5
			Wy	0.28	0.33	0.38		
	Red		Rx	0.523	0.573	0.623		
			Ry	0.300	0.350	0.400		
	Green		Gx	0.286	0.336	0.386		
		Gy	0.547	0.597	0.647			
	Blue	Bx	0.102	0.152	0.202			
		By	0.062	0.112	0.162			
Viewing Angle	Hor.	Θ_R	CR 10	60	70	-	Degree	Note:1
		Θ_L		60	70	-		
	Ver.	Φ_T		40	50	-		
		Φ_B		50	60	-		
Brightness	-	-	200	250	-	Cd/m ²	Note:6	
Uniformity				80		%	Note:7	

Note 1: Definition of viewing angle range

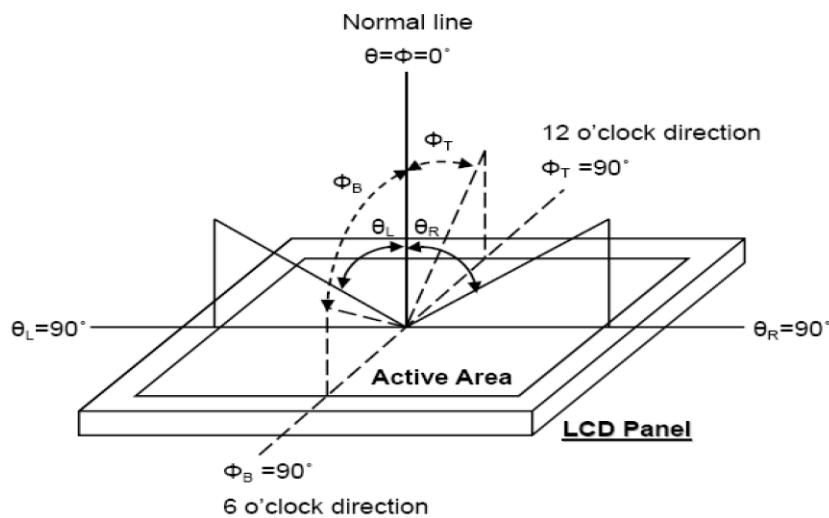

Fig.10-1 Definition of viewing angle

Note 2: Test equipment setup:

After stabilizing and leaving the panel alone at a driven temperature and Adj=3.3V for 10 minutes, the measurement should be executed. Measurement should be executed in a stable, windless, and dark room. Optical specifications are measured by Topcon BM-7A luminance meter 1.0° field of view at a distance of 50cm and normal direction.

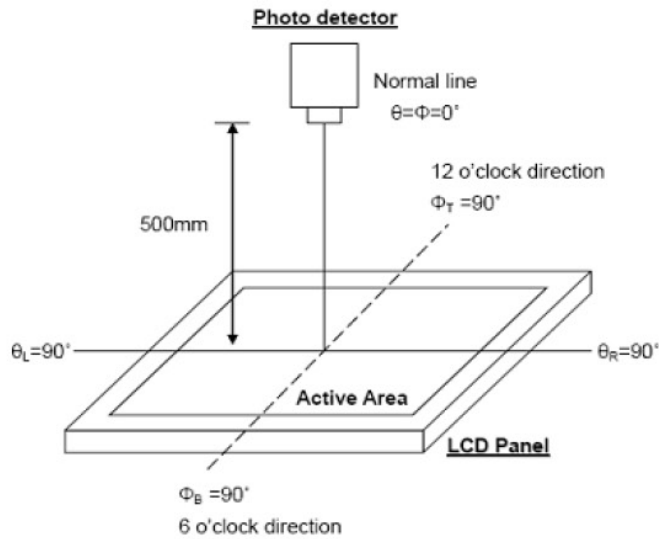

Fig. 10-2 Optical measurement system setup

Note 3: Definition of Response time:

The response time is defined as the LCD optical switching time interval between and “Black” state. Rise time, T_r , is the time between photo detector output intensity changed from 90% to 10%. And fall time, T_f , is the time between photo detector output intensity changed from 10% to 90%.

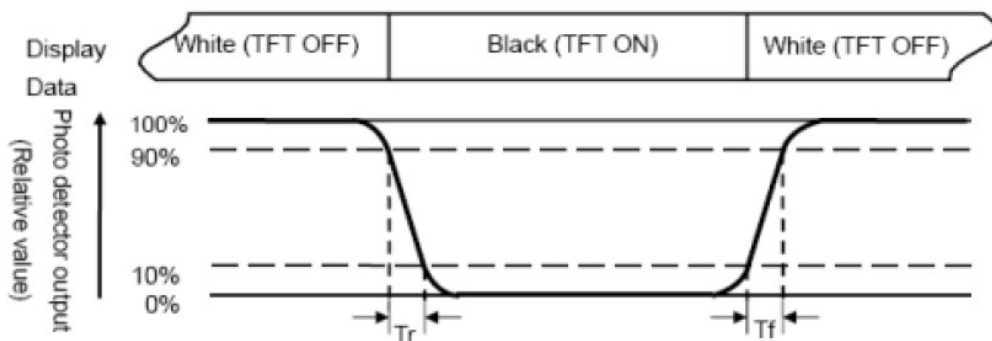

Fig 10-3 Definition of response time

Note 4: Definition of contrast ratio:

The contrast ratio is defined as the following expression.

$$CR = \frac{\text{Luminance measured when LCD on the "white" state}}{\text{Brightness measured when LCD on the "black" state}}$$

Note 5: Definition of color chromaticity (CIE 1931)

Color coordinates measured at the center point of LCD

Note 6: Measured at the center area of the panel when all the input terminals of LCD panel are electrically opened.

Note 7:

$$\text{Uniformity} = \frac{\text{Brightness}(\text{min})}{\text{Brightness}(\text{max})} \times 100\%$$

11. INTERFACE

Pin No	Symbol	Function	Remark
1	VCC	power supply for Digital Circuit	
2	VCC	power supply for Digital Circuit	
3	GND	Ground	
4	GND	Ground	
5	RxIN0-	Differential Data Input ,CH0(Negative)	
6	RxIN0+	Differential Data Input ,CH0(Positive)	
7	GND	Ground	
8	RxIN1-	Differential Data Input ,CH1(Negative)	
9	RxIN1+	Differential Data Input ,CH1(Positive)	
10	GND	Ground	
11	RxIN2-	Differential Data Input ,CH2(Negative)	
12	RxIN2+	Differential Data Input ,CH2(Positive)	
13	GND	Ground	
14	CKIN-	Differential Clock Input (Negative)	
15	CKIN+	Differential Clock Input (Positive)	
16	GND	Ground	
17	VDD	Power Supply for LED Driver Circuit	
18	VDD	Power Supply for LED Driver Circuit	
19	GND	Ground	
20	ADJ	Brightness control for LED B/L	

Remarks :

- 1) ADJ is brightness control Pin. The larger of the pulse duty is, the higher of the brightness.
- 2) ADJ signal is 0~3.3V.Operation frequency is 20 KHz
- 3) GND PIN must be grounding, can not be floating.

12. BLOCK DIAGRAM

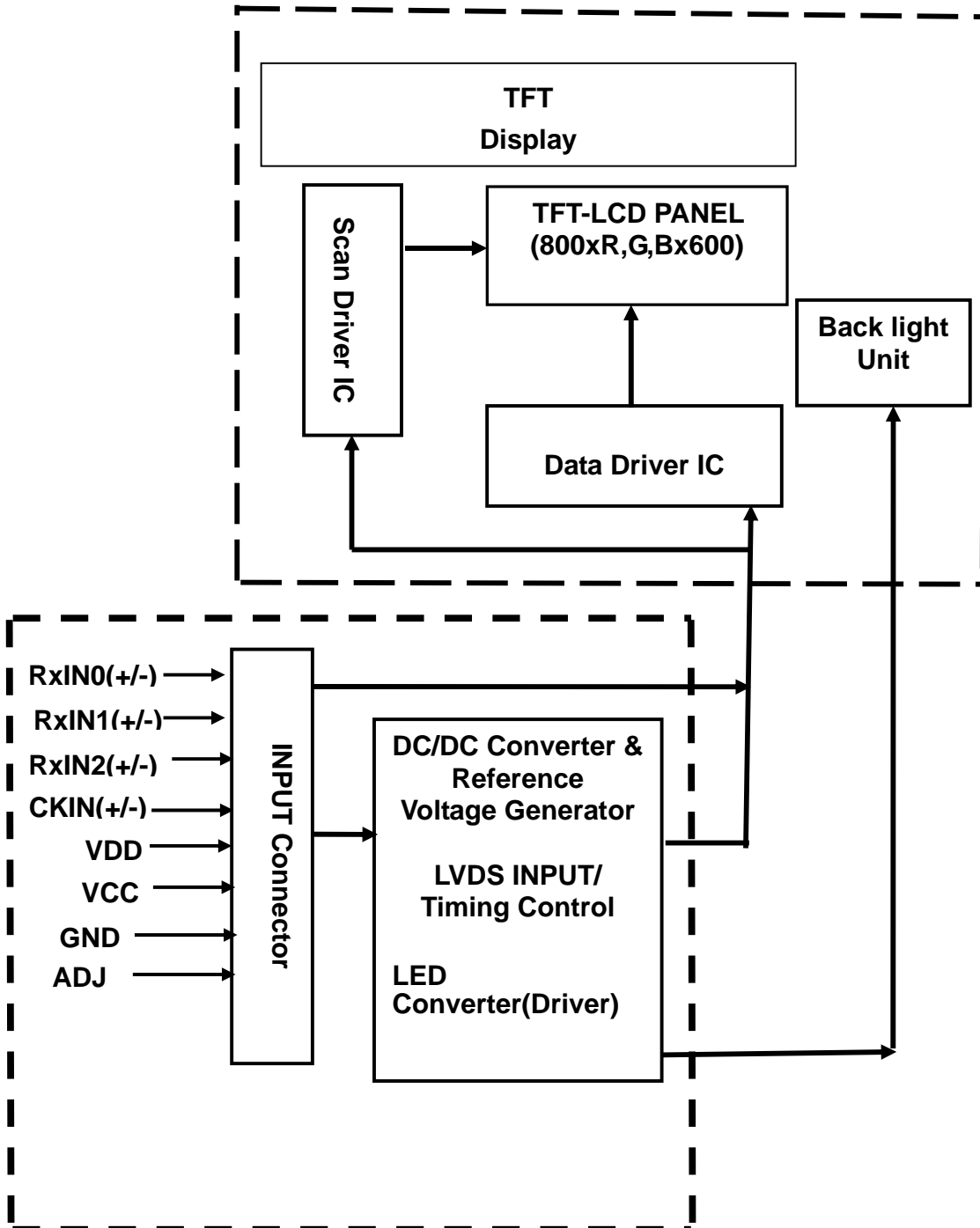

13.QUALITY ASSURANCE

13.1 Test Condition

13.1.1 Temperature and Humidity(Ambient Temperature)

Temperature : $25 \pm 5^{\circ}\text{C}$

Humidity : $65 \pm 5\%$

13.1.2 Operation

Unless specified otherwise, test will be conducted under function state.

13.1.3 Container

Unless specified otherwise, vibration test will be conducted to the product itself without putting it in a container.

13.1.4 Test Frequency

In case of related to deterioration such as shock test. It will be conducted only once.

13.1.5 Test Method

Reliability Test Item & Level		Test Level
No.	Test Item	
1	High Temperature Storage Test	Ta=60 , Dry 240hrs
2	Low Temperature Storage Test	Ta=-20 , Dry 240hrs
3	High Temperature Operation Test	Ta=50 , Dry 240hrs
4	Low Temperature Operation Test	Ta=-10 , Dry 240hrs
5	High Temperature and High Humidity Operation Test	Ta=50 ,80%RH,240hrs
6	Electro Static Discharge Test (No operation)	150pF, 330 , $\pm 6\text{KV}(\text{Contact})/\pm 8\text{KV}(\text{Air})$,
7	Thermal Cycling Test (No operation)	-20 \rightarrow +25 , \rightarrow 60 100 Cycles (Dry) 30 min 5 min 30 min
8	Vibration Test (No operation)	Frequency :10 ~ 55 HZ Amplitude :1.5 mm Sweep time : 11 mins Test Period: 6 Cycles for each direction of X, Y, Z
9	Shock Test (No operation)	100G, 6ms Direction: $\pm X, \pm Y, \pm Z$ Cycle: 3 times

* Ta= Ambient Temperature

Note 1: The test samples have recovery time for 4 hours at room temperature before the function check. In the standard conditions, there is no display function NG issue occurred.

Note 2: All the cosmetic specifications are judged before the reliability stress.

14. LCM PRODUCT LABEL DEFINE

Product Label style:

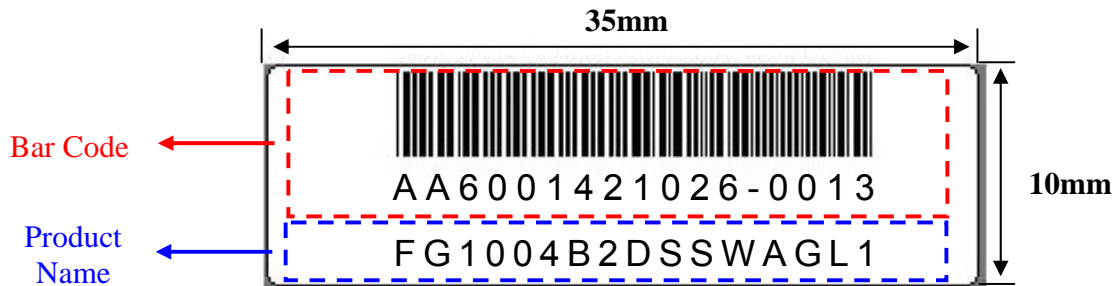

BarCode Define:

A A 6 0014 2 10 26-0013

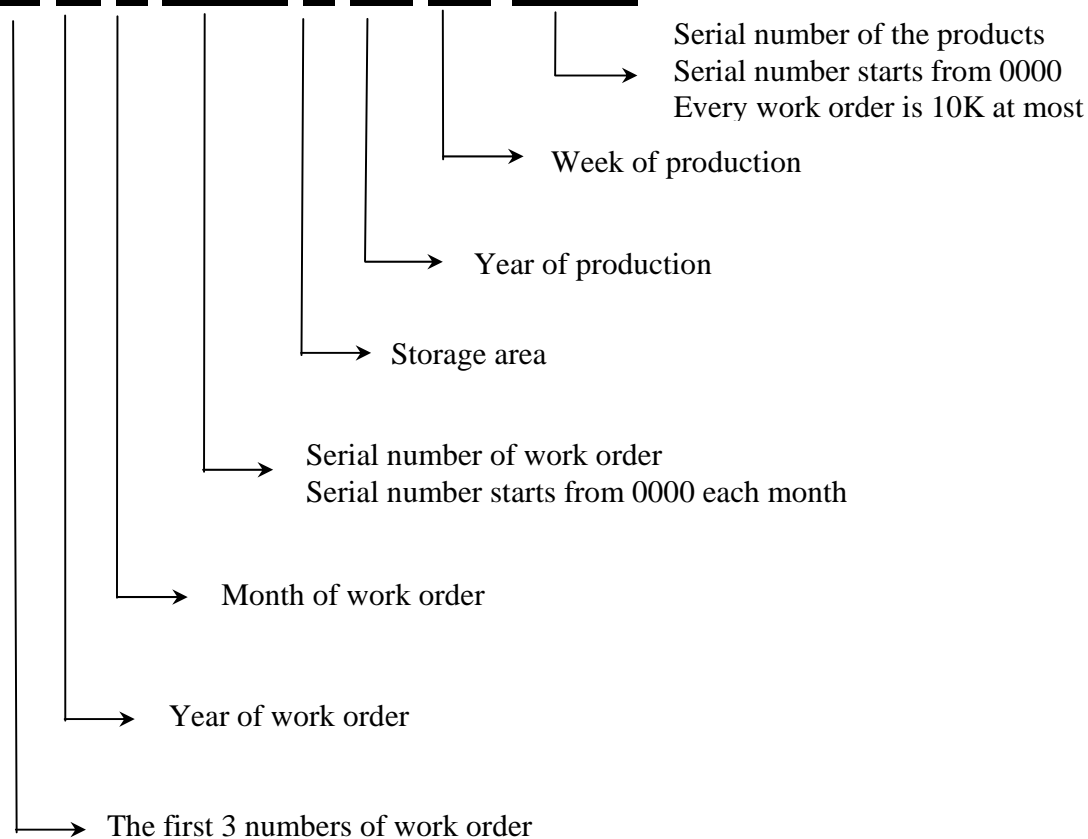

Product Name Define:

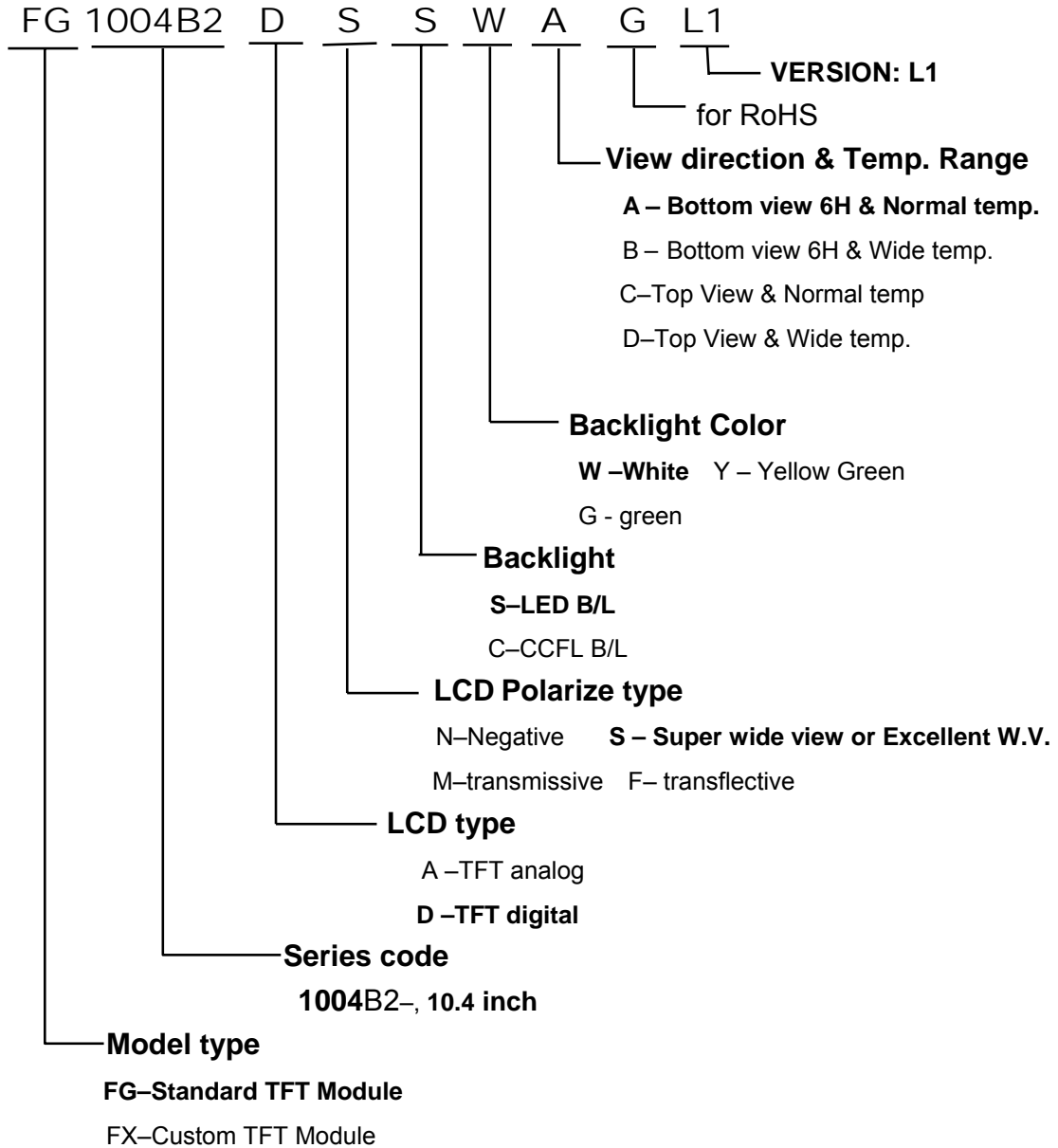

15. PRECAUTIONS IN USE LCM

1. ASSEMBLY PRECAUTIONS

- (1) You must mount a module using holes arranged in four corners or four sides.
- (2) You should consider the mounting structure so that uneven force (ex. Twisted stress) is not applied to the module. And the case on which a module is mounted should have sufficient strength so that external force is not transmitted directly to the module.
- (3) Do not touch, push or rub the exposed polarizers with glass, tweezers or anything harder than HB pencil lead. And please do not rub with dust clothes with chemical treatment.
- (4) Wipe off saliva or water drops as soon as possible. Their long time contact with polarizer causes deformations and color fading.
- (5) Do not open the case because inside circuits do not have sufficient strength.
- (6) Please do not take a LCD module to pieces and reconstruct it. Resolving and reconstructing modules may cause them not to work well.
- (7) Please do not touch metal frames with bare hands and soiled gloves. A color change of the metal frames can happen during a long preservation of soiled LCD modules.
- (8) Please pay attention to handling lead wire of backlight so that it is not tugged in connecting with inverter.

2. OPERATING PRECAUTIONS

- (1) Please be sure to turn off the power supply before connecting and disconnecting signal input cable.
- (2) Please do not change variable resistance settings in LCD module. They are adjusted to the most suitable value. If they are changed, it might happen LCD does not satisfy the characteristics specification
- (3) Be careful for condensation at sudden temperature change. Condensation makes damage to polarizer or electrical contacted parts. And after fading condensation, smear or spot will occur.
- (4) When fixed patterns are displayed for a long time, remnant image is likely to occur.
- (5) Module has high frequency circuits. Sufficient suppression to the electromagnetic interference shall be done by system manufacturers. Grounding and shielding methods may be important to minimize the interference.
- (6) Please consider that LCD backlight takes longer time to become stable of radiation characteristics in low temperature than in room temperature.

3. ELECTROSTATIC DISCHARGE CONTROL

- (1) The operator should be grounded whenever he/she comes into contact with the module. Never touch any of the conductive parts such the copper leads on the PCB and the interface terminals with any parts of the human body.

- (2) The modules should be kept in antistatic bags or other containers resistant to static for storage.
- (3) Only properly grounded soldering irons should be used.
- (4) If an electric screwdriver is used, it should be well grounded and shielded from commutator sparks.
- (5) The normal static prevention measures should be observed for work clothes and working benches; for the latter conductive (rubber) mat is recommended
- (6) Since dry air is inductive to statics, a relative humidity of 50-60% is recommended.

4. STORAGE PRECAUTIONS

- (1) When you store LCDs for a long time, it is recommended to keep the temperature between 0°C-40°C without the exposure of sunlight and to keep the humidity less than 90%RH.
- (2) Please do not leave the LCDs in the environment of high humidity and high temperature such as 60°C 90%RH
- (3) Please do not leave the LCDs in the environment of low temperature; below -20°C.

5. OTHERS

- (1) A strong incident light into LCD panel might cause display characteristics' changing inferior because of polarizer film, color filter, and other materials becoming inferior. Please do not expose LCD module direct sunlight and strong UV rays
- (2) Please pay attention to a panel side of LCD module not to contact with other materials in preserving it alone.
- (3) For the packaging box, please pay attention to the followings:
 - a. Please do not pile them up more than 5 boxes. (They are not designed so.) And please do not turn over.
 - b. Please handle packaging box with care not to give them sudden shock and vibrations. And also please do not throw them up.
 - c. Packing box and inner case for LCDs are made of cardboard. So please pay attention not to get them wet. (Such like keeping them in high humidity or wet place can occur getting them wet.)

6. LIMITED WARRANTY

Unless otherwise agreed between DATA IMAGE and customer, DATA IMAGE will replace or repair any of its LCD and LCM which is found to be defective electrically and visually when inspected in accordance with DATA IMAGE acceptance standards, for a period on one year from date of shipment. Confirmation of such date shall be based on freight documents. The warranty liability of DATA IMAGE is limited to repair and/or replacement on the terms set forth above. DATA IMAGE will not responsible for any subsequent or consequential events.

Confidential Document
16. OUTLINE DRAWING

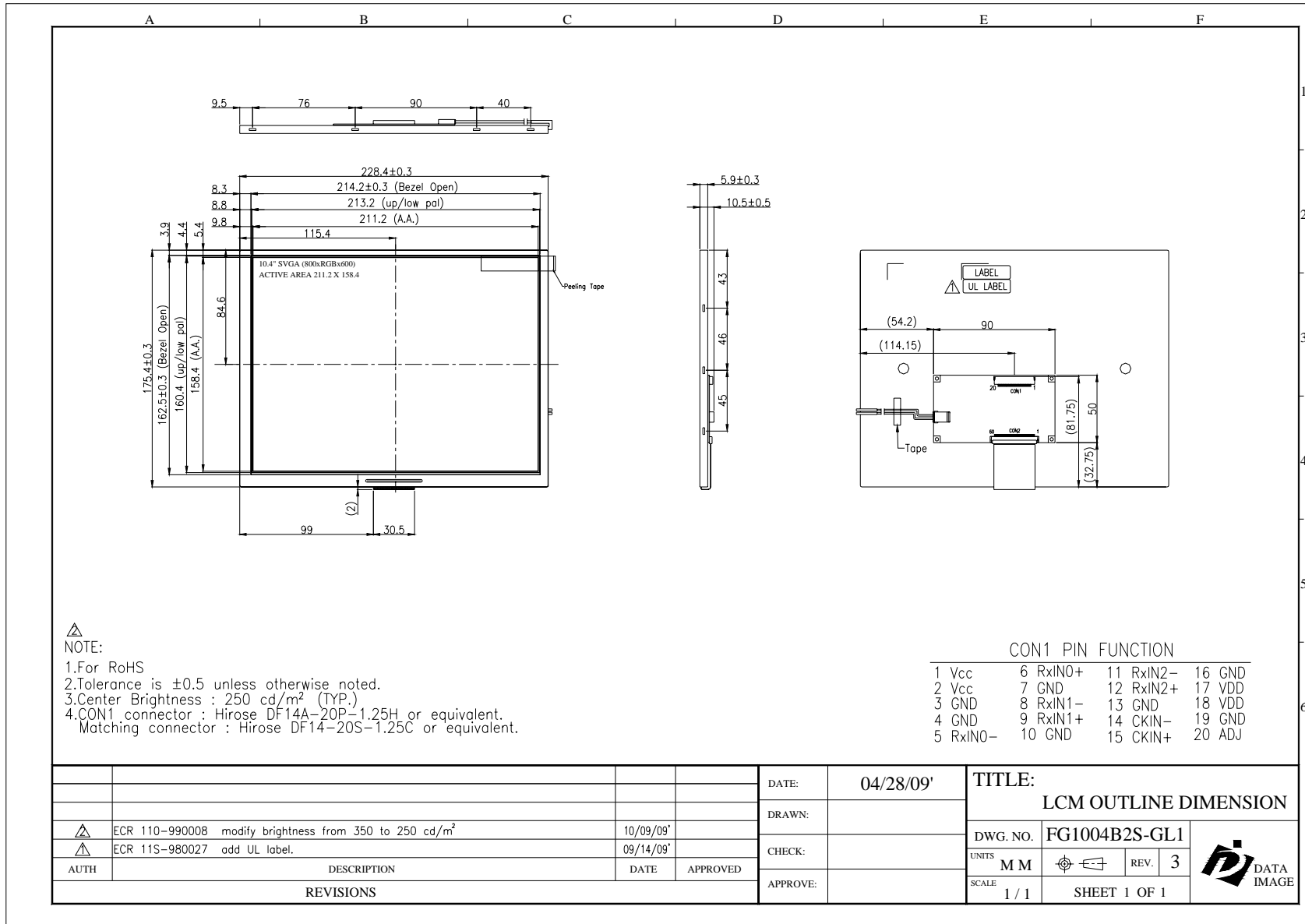



Confidential Document

17.PACKAGE INFORMATION

TBD